



Owners Manual

Envirosun[®] Heat Pump Water Heater

ES200M19 / ES330M19



IMK22861
AS/NZS 2712



WaterMark
WM-022861
AS 3498



THIS PAGE INTENTIONALLY LEFT BANK.

INSTALLATION RECORD

PLEASE COMPLETE THIS PAGE AS A RECORD OF THE INSTALLATION DETAILS FOR YOUR REFERENCE TO DETERMINE WHEN THE SYSTEM IS DUE FOR SERVICE OR IF A WARRANTY MATTER SHOULD ARISE.

SCAN THE QR CODE WITH YOUR PHONE AND REGISTER YOUR WARRANTY ONLINE.

Energie Group Pty Ltd
ABN 50 166 500 787
460 Victoria Road
Malaga WA 6090



IMPORTANT!
REGISTER YOUR
WARRANTY



envirosun.au/warranty

.....
Owner Name

.....
Installation Address

.....
Suburb

.....
State

.....
Telephone (Home)

.....
(Work)

.....
Email

..... / /
Date

.....
System Model Number

.....
Tank Serial Number

.....
Installer Name

.....
Installer Address

.....
Installer Telephone

.....
Comments

.....
Customer Signature

.....
Installer Signature

..... / /
Date

THIS PAGE INTENTIONALLY LEFT BANK.

CONTENTS

IMPORTANT SAFETY INFORMATION	3	Initial power on	19
Interpretation of marks and symbols	3	Temperature setting	19
Loading and unloading requirements	4	Screen lighting time	19
Transport requirements	4	Boost mode	19
Storage requirements	4	Auto mode	19
Scrapping and recovery requirements	4	Timer mode	20
Draining and flushing the system	4	Same heating schedule	20
FUNCTIONING & PRINCIPLE OF OPERATION	5	Different heating schedule	20
INSTALLATION INSTRUCTIONS	7	Electric mode	20
Transporting the appliance	7	Mute mode	20
Selection of installation site	7	Wi-Fi setup and smartphone app guide	21
Installation dimensions and clearances	8	App download	21
DESCRIPTION OF PARTS AND COMPONENTS (200L)	9	Account registration	21
200L heat pump layout	9	Activate the Wi-Fi module	21
Carton contents	9	App pairing steps	21
Exploded view of the 200L heat pump	10	MAINTENANCE	22
DESCRIPTION OF PARTS AND COMPONENTS (330L)	11	Draining and flushing the system	22
330L heat pump layout	11	Relief valves	22
Carton contents	11	Condensate discharge pipe	22
Exploded view of the 330L heat pump	12	Anode replacement	22
PLUMBING INSTALLATION	13	Water quality	23
Piping installation diagram	13	TROUBLESHOOTING	23
Seismic strapping	14	Hot water use higher than anticipated	23
ELECTRICAL INSTALLATION	15	Water discharge through the pressure relief valve	23
Electrical safety requirements	15	FAULTS AND PROTECTION	24
COMMISSIONING CHECK LIST	15	STANDARD WARRANTY	25
System location	15	Warranty terms	25
Water system piping	15	Warranty conditions	25
Electrical connections	15	Warranty exclusions	26
OPERATION AND FUNCTIONS	16	OH&S Disclaimer	27
Functions and protections	16	CONTACT DETAILS	27
Display screen	16		
Description of the icons	17		

Thank you for choosing Envirosun products.

Please read this manual carefully and follow the operation and safety instruction to ensure best installation and utilisation of the product.

1. This appliance is not intended for use by persons with reduced physical, sensory or mental capabilities, persons with a lack of experience and knowledge, or children under the age of 8 years. Persons in this group must be supervised while using the appliance by a person responsible for their safety.
2. Children should be supervised to ensure that they do not play with the appliance.
3. Installation must be carried out by qualified professionals. Do not open the cover or panel unless qualified to undertake this work. Contact Envirosun if service or repair work is required.
4. This appliance must be permanently connected to mains water supply and continuous electrical supply.
5. This product complies with AS3498:2020

WARNING – FLAMMABLE HAZARD!



1. Please read the instructions carefully before installation and use of this appliance.
2. Do not puncture or ignite this product.
3. The environment-friendly refrigerant R290 used in this product is odourless.



4. This product must be installed outdoors.
5. This product cannot be discarded or scrapped without correct retrieval of the refrigerant. If necessary, please contact Envirosun to obtain the correct disposal method.



6. The product must not be stored in an area containing an open flame such as an open fire, gas appliance or electric heater.



7. Before the refrigeration system is repaired, the refrigerant must be removed by a qualified professional.
8. Do not use any method to accelerate the defrosting process or clean frosted components of the appliance.



WARNING

RISK OF DAMAGE TO THE ENVIRONMENT

This heat pump contains R290 refrigerant. This refrigerant must not escape into the atmosphere. Refrigerant must be removed and disposed of by a qualified professional.



WARNING

WARNING – FOR CONTINUED SAFETY OF THIS APPLIANCE IT MUST BE INSTALLED, OPERATED AND MAINTAINED IN ACCORDANCE WITH THE MANUFACTURER'S INSTRUCTIONS.



WARNING

WARNING – THIS APPLIANCE MAY DELIVER WATER AT HIGH TEMPERATURE!

REFER TO THE PLUMBING CODE OF AUSTRALIA (PCA), LOCAL REQUIREMENTS AND INSTALLATION INSTRUCTIONS TO DETERMINE IF ADDITIONAL DELIVERY TEMPERATURE CONTROL IS REQUIRED.

IMPORTANT SAFETY INFORMATION

Interpretation of marks and symbols

Failure to follow these instructions may lead to serious malfunctions of the device and danger to the user.



WARNING Instructions marked with this symbol must be followed. Failure to do so may lead to product damage and harm to the user.



 Instructions with this mark relate to important installation requirements that ensure the correct operation of the device.



FORBIDDEN **INFORMATION MARKED WITH THIS SYMBOL ARE FORBIDDEN.**
FAILURE TO FOLLOW THIS INSTRUCTION MAY LEAD TO PRODUCT DAMAGE AND HARM TO THE USER.



WARNING The water heater shall be installed in strict accordance with local wiring regulations. The power supply must have a grounding line. Ensure an effective ground connection.



WARNING The outlet water temperature of a water heater is typically higher than the temperature indicated on the display. Ensure that contact to hot water directly leaving the appliance cannot occur.



FORBIDDEN **GROUND AND NEUTRAL LINES OF THE POWER SUPPLY MUST NOT BE CONNECTED.**
THE GROUND LINE SHALL NOT BE CONNECTED TO GAS OR WATER PIPES, LIGHTNING ARRESTERS OR TELEPHONE LINES.



WARNING This appliance must be installed with an isolation switch to the power supply. This switch must ensure full disconnection and be in accordance with the wiring rules.



 The water heater must be installed in a location where suitable water drainage is possible.



WARNING Install the water heater in strict accordance with these installation instructions. If the power cord is damaged, it must be replaced by a qualified professional.



 The water heater must be installed outside.



WARNING Do not put hands or other items into the air grid. This may cause injury or damage to the appliance.

 This appliance must be fitted with the pressure temperature relief valve (PTR valve) supplied with the appliance. The PTR valve must be fitted directly to the appliance.

 The PTR valve drain must be installed in a continuously downward direction, be open to the atmosphere, be free from blockages, and the potential to frost.

WARNING While bathing, children must be under guidance of an adult. Children must not play with the appliance.

WARNING The PTR valve must be operated every six months to remove lime deposits, and to ensure that it is free from blockages.

WARNING IF THE HOT WATER SYSTEM IS NOT USED FOR TWO WEEKS OR MORE, A QUANTITY OF HIGHLY FLAMMABLE HYDROGEN GAS MAY ACCUMULATE IN THE WATER HEATER. TO DISSIPATE THIS GAS SAFELY, IT IS RECOMMENDED THAT A HOT TAP BE TURNED ON FOR SEVERAL MINUTES OR UNTIL DISCHARGE OF GAS CEASES. USE A SINK, BASIN, OR BATH OUTLET, BUT NOT A DISHWASHER, CLOTHES WASHER, OR OTHER APPLIANCE. DURING THIS PROCEDURE, THERE MUST BE NO SMOKING, OPEN FLAME, OR ANY ELECTRICAL APPLIANCE OPERATING NEARBY. IF HYDROGEN IS DISCHARGED THROUGH THE TAP, IT WILL PROBABLY MAKE AN UNUSUAL SOUND AS WITH AIR ESCAPING.

1. Installation, service, or maintenance of this appliance must be carried out by a qualified professional. Failure to adhere to this may result in damage to the appliance or other property, or cause injury.
2. Fit the appliance in accordance with this installation manual.
3. Be sure to use only certified parts and accessories in the installation of this appliance.
4. Install the product on a base that can hold the filled weight of the appliance.
5. Electrical work must be performed in accordance with all local standards and regulations, including AS/NZS3000, and the instructions in this manual.
6. This appliance must be connected to a dedicated electrical circuit.
7. During installation, ensure that the ground wire is disconnected last.
8. If a refrigerant leak occurs, ventilate the area immediately. The refrigerant is flammable, so damage or injury is possible if it reaches an open flame.
9. Be aware that the refrigerant contained in this appliance does not have an odour.
10. Do not accelerate the defrosting process or clean the evaporator when frosted. Only a qualified person should clean the evaporator.
11. Do not pierce or burn this appliance.
12. This appliance must be installed outside and be well ventilated. A gas leak in a poorly ventilated area could create an explosion risk.
13. Prevent insects and small animals entering the appliance. This may cause electrical shorts, malfunctions or fire.
14. Only qualified personnel can handle, fill, purge and dispose of the refrigerant in this appliance.
15. If installed in a coastal or high sulfate gas region, corrosion will occur shortening the appliance life.

Loading and unloading requirements

1. This appliance shall be carefully handled during transport loading and unloading.
2. Ensure that the appliance is not dropped, bumped, or rolled during transportation as this could cause damage to the appliance, potentially creating a refrigerant leak.

Transport requirements

1. Local transport regulations should be consulted to determine the maximum allowable appliance quantity or refrigerant (R290) volume that can be transported at any one time.

Storage requirements

1. As this appliance contains a flammable refrigerant R290, its storage must be in accordance with local regulations.
2. The storage should ensure that there is no potential for damage to the appliance. Any damage could result in a refrigerant leak.

Scraping and recovery requirements

1. Scraping must only be carried out by a qualified professional. This professional must safely recover the appliance's refrigerant before the appliance is scrapped. Contact EnviroSun to correctly dispose of this appliance.

Draining and flushing the system



CAUTION

The system must be completely drained of water before any plumbing work is commenced. This will prevent damage to the storage tank in the event of a vacuum or excessive pressure forming at the storage tank.



The heat pump hot water system should be drained and flushed every five years during a major service of the unit.

1. Turn off and isolate the power supply to the electrical element.
2. Turn off the water supply to the water heater.
3. Release excess pressure from the tank by manually opening the pressure & temperature relief valve.
4. Disconnect the cold water supply pipe connection to the tank.
5. Fit a ½" flexible drain pipe to the cold connection at the tank. Place the open end of the drain hose in a location where it is safe for the hot water to drain away from the tank.
6. Manually open the pressure & temperature relief valve which will allow air into the tank and the water within the tank will flow out via the flexible drain pipe fitted to the cold inlet connection. Hold the valve open until the tank is empty.

FUNCTIONING & PRINCIPLE OF OPERATION

Your Envirosun system is called a heat pump because it collects heat from the ambient air and “pumps” it into the water in the storage vessel. This is done in much the same way that an air conditioner removes heat from a room and expels it to the outside air.

A refrigerant is used to transfer the heat via a compressor to a heat exchanger wrapped around the storage tank. As the refrigerant delivers its heat to the water, it cools and condenses, and then passes through an expansion valve where the pressure is reduced, and the cycle starts over. This process, called the Rankine Cycle, has been used for over a century for refrigeration and air conditioning applications and has been used for energy efficient water heating for decades.

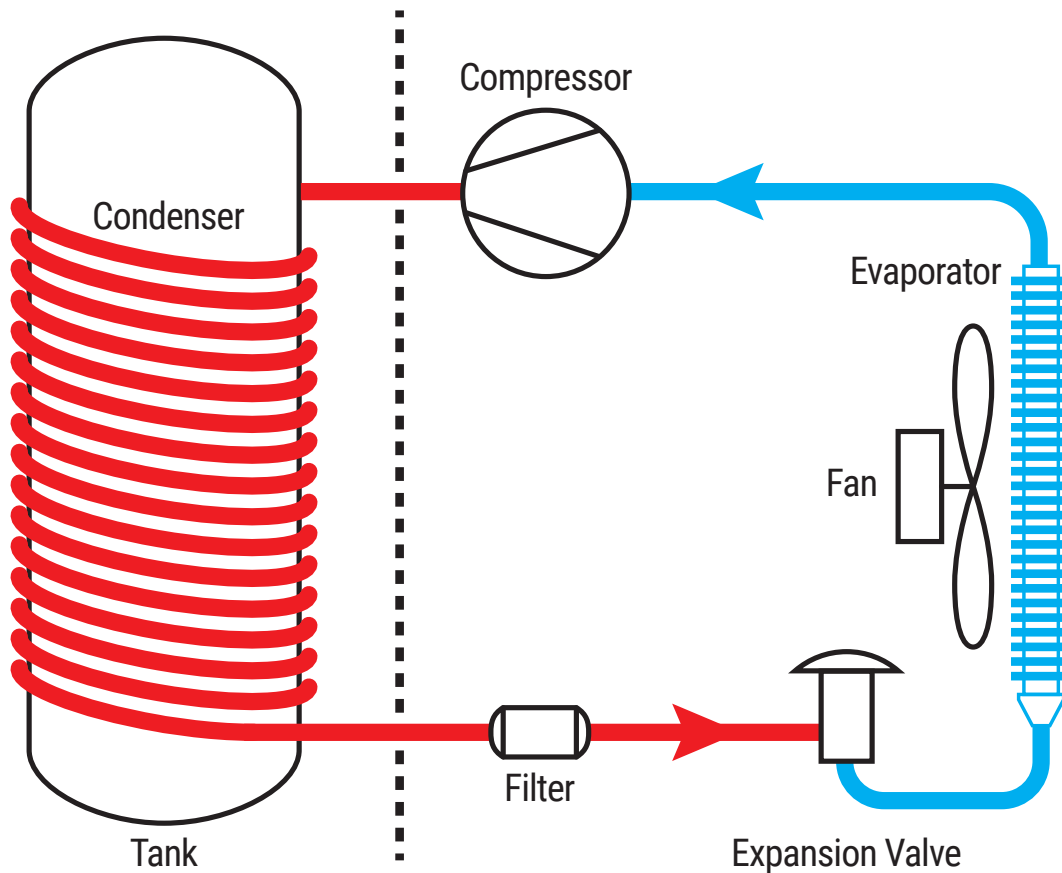

HOW IT WORKS

To understand the concept of heat pumps, imagine a refrigerator working in reverse.

While a refrigerator removes heat from an enclosed box and expels that heat to the surrounding air, a heat pump takes the heat from surrounding air and transfers it to water in an enclosed tank.

Heat pump technology makes efficient use of the heat in the surrounding air, even at temperatures as low as -7°C .

In fact, the Envirosun system is so efficient that it can **convert 1kW of electricity into over 4kW of heat.**

TECHNICAL SPECIFICATIONS

Model	ES200M9	ES330M9
Total water capacity	190L	330L
Rated voltage / frequency	220-240V/50Hz	220-240V/50Hz
Tank max pressure	700kPa	700kPa
Corrosion protection	Magnesium rod	Magnesium rod
Waterproof grade	IPX4	IPX4
Performance (20°C/15°C Ambient air temperature, 15°C -55°C water temperature)		
COP*1@ 20°C/15°C	4.16	4.04
Power input of electric element	1500W	1500W
Rated power input of heat pump	780W	820W
Maximum power input of heat pump	1500W	1500W
Maximum power input	1500W	1500W
Average heating capacity by heat pump	3200W	3300W
Default temperature setting	60°C	60°C
Temperature setting range - with heater	60°C – 75°C	60°C – 75°C
Maximum temperature of the heat pump only	65°C	65°C
Maximum working pressure of refrigerant	1.0/3.3MPa	1.0/3.3MPa
Refrigerant type / weight	R290/0.42kg	R290/0.47kg
Sound pressure level*2	42dB(A)	42dB(A)
Ambient temperature for heat pump and element	-7~45°C	-7~45°C
Ambient temperature of heat pump	-7~45°C	-7~45°C
Water inlet and outlet connection	Rp ¾"	Rp ¾"
TPR valve connection	Rp ¾"	Rp ¾"
Drain & Water inlet connection	Rp ¾"	Rp ¾"
Product Dimensions	580 x 620 x 1746mm	710 x 740 x 1923mm
Packing dimension with pallet	695 x 695 x 2060mm	745 x 745 x 2263mm
Net/Gross weight	93/119kg	119/148kg
Filled weight of the appliance	282kg	449kg

*1 The COP was measured under test conditions with an ambient air temperature of 20°C/15°C (Dry Bulb/Wet Bulb) and heating of the water from 15°C to 55°C during water heater operation. COP will vary according to system conditions and is not an accurate indication of system performance.

*2 The noise level was measured at 2m from the water heater in Mute mode.

INSTALLATION INSTRUCTIONS

Transporting the appliance

1. During transport or storage, the heat pump water heater should remain in undamaged packaging to prevent damage to the appliance.
2. During long periods of transport or storage, the heat pump water heater must be in an upright position.
3. For short distance transportation (under one hour), this product may be laid down within 1 hour as per indication on packaging. If laid down, the appliance must be at an upright position for 4 hours prior to its initial startup.

Selection of installation site

1. Ensure the install location is stable and level, and that air can flow in and out freely, and will be minimally affected by wind.
2. The base or surface can support the filled weight of the appliance and the condensate water can be drained freely.
3. If installed on a base, ensure that this base is level to allow correct drainage via the condensate drain at the rear of the appliance.
4. The location or position of the appliance will not create nuisance noise for the homeowners or neighbors, especially through proximity to bedrooms.
5. Ensure that the location allows condensate and PTR valves to be drained into an area that will not cause damage to the surrounding area.
6. There is sufficient space left for installation and maintenance of the appliance.
7. There is no strong electromagnetic interference around the appliance that may affect its control functions.
8. There are no corrosive vapors such as aerosol sprays, stain removers or household chemicals near the install location. These vapors may corrode the appliance and its fittings.
9. Considerations have been made to prevent water pipes from freezing in colder regions.

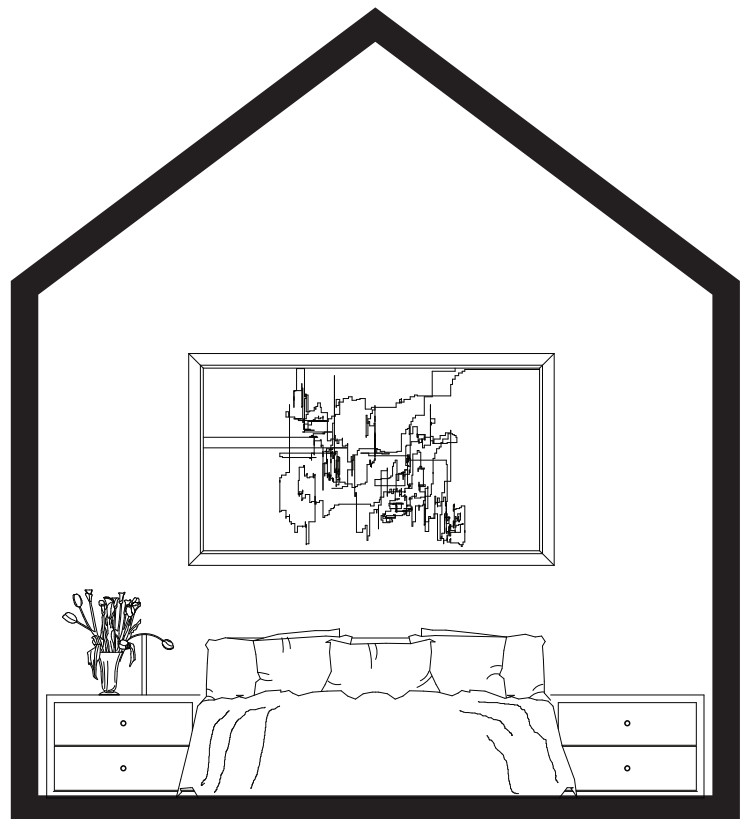
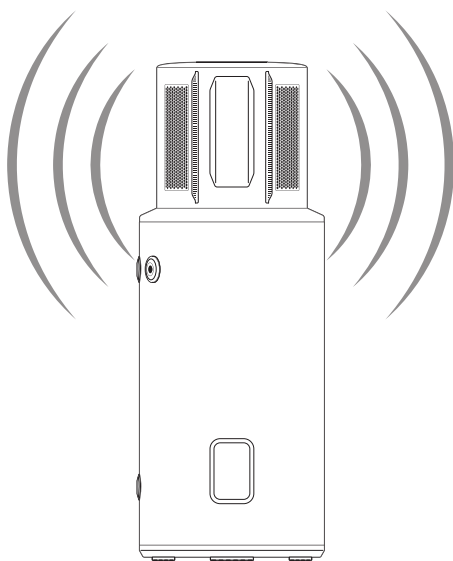

Installation dimensions and clearances

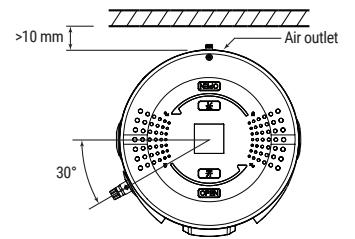
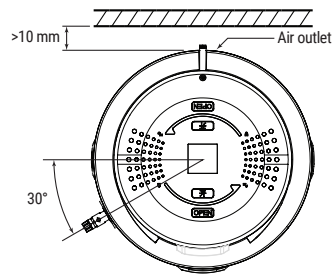
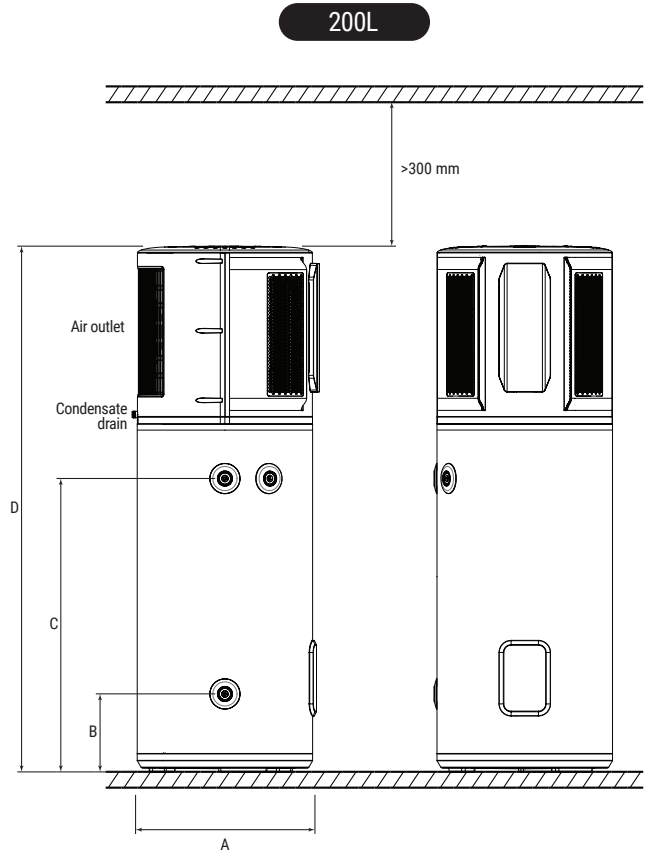
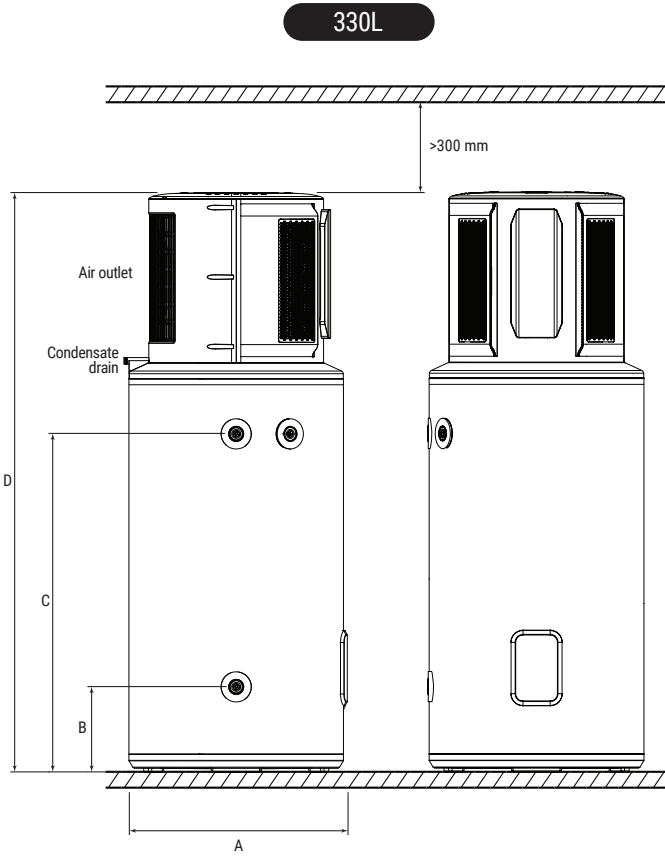

Model	A	B	C	D
ES200M9	620	258	970	1746
ES330M9	740	282	1119	1923

Note: This appliance must be installed in a location where it can be quickly and easily drained and moved to an area with at least 1000mm clearance above it. This is necessary to allow the anodes to be removed for inspection and replacement during the five-year service.

DESCRIPTION OF PARTS AND COMPONENTS (200L)

200L heat pump layout

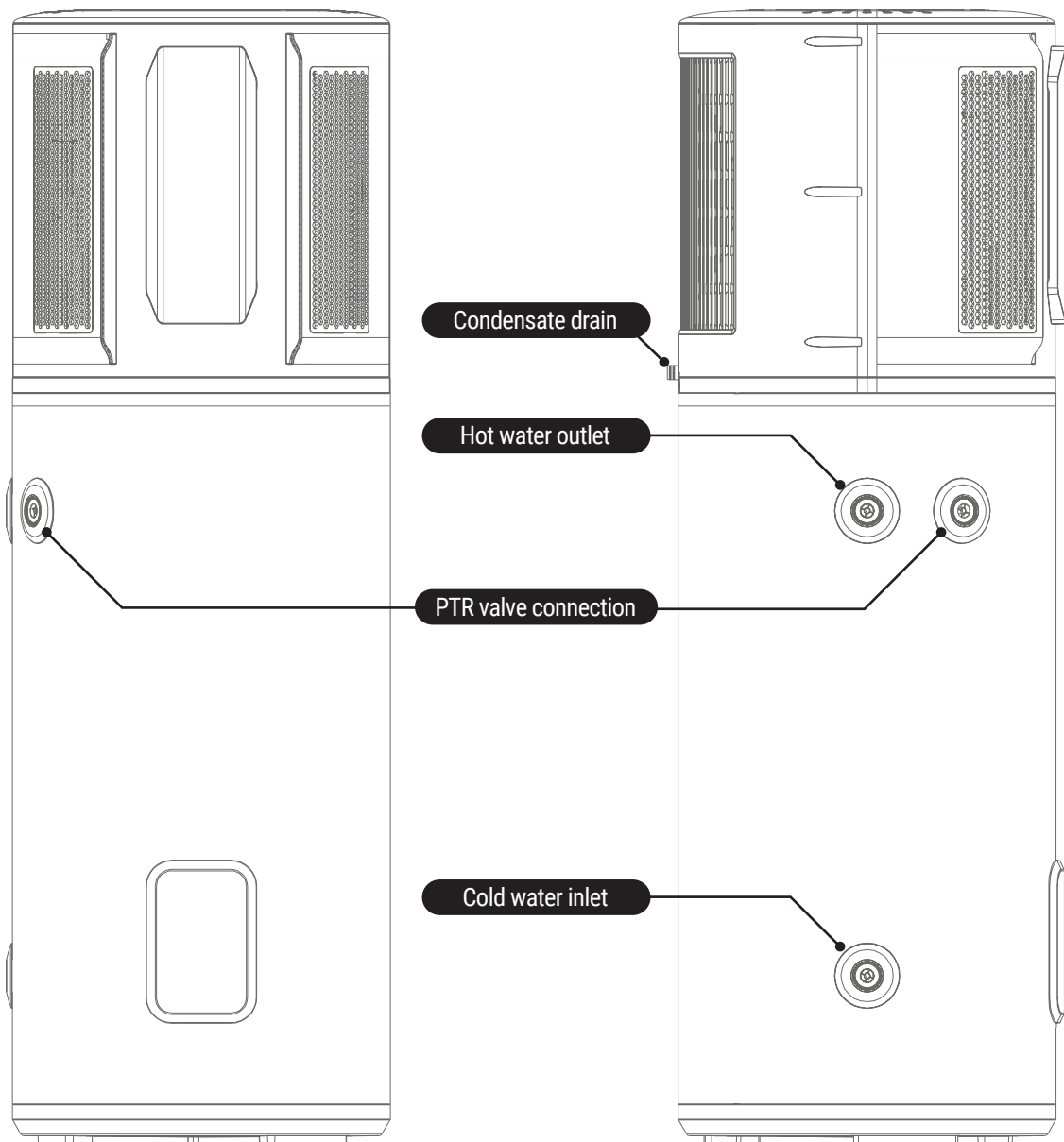

Carton contents

Part Name	Heat Pump Water Heater	Instruction Manual	PTR Valve
Quantity	1	1	1

Exploded view of the 200L heat pump

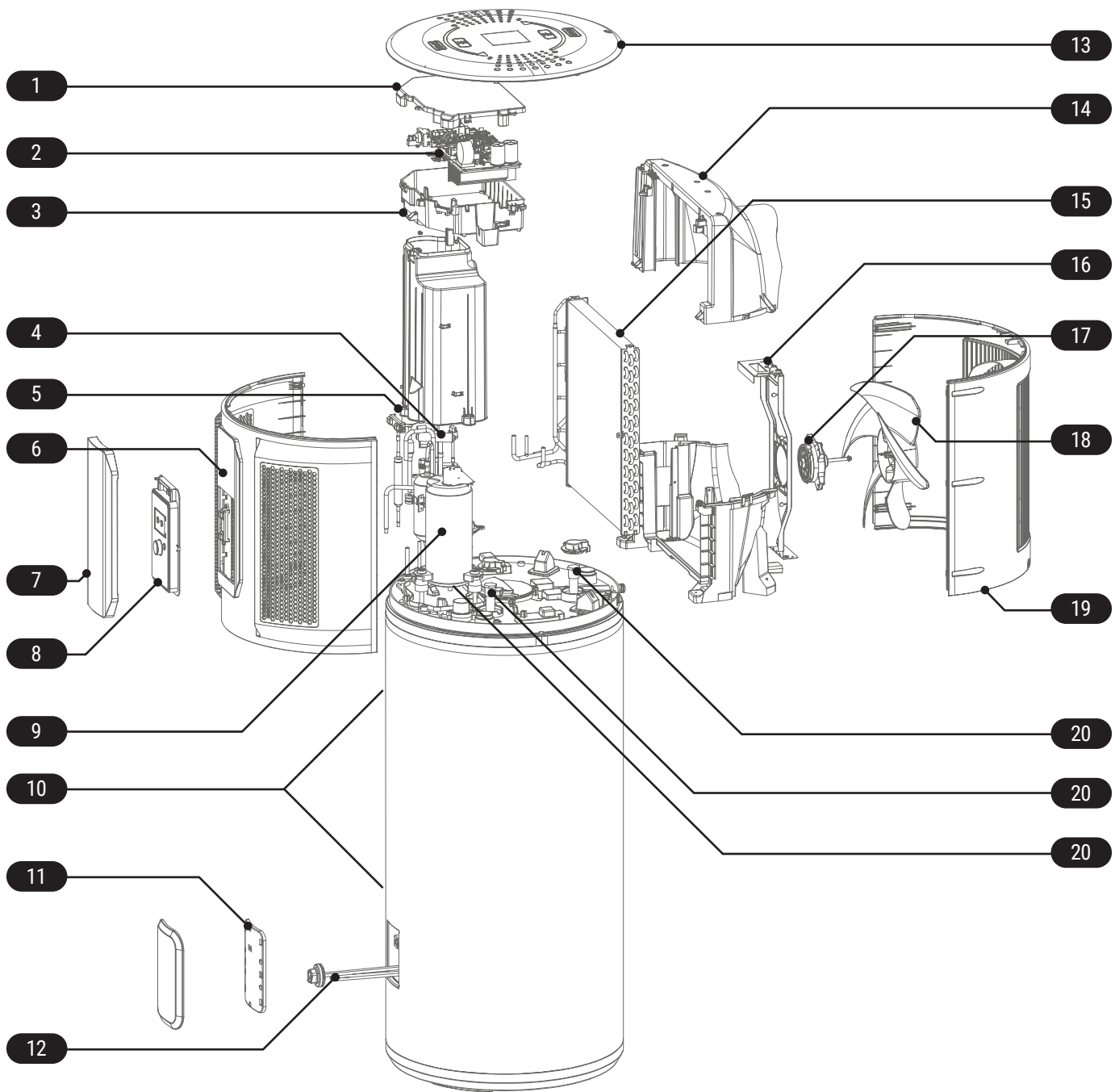

1	Electrical box cover	11	Waterproof cover
2	Electronic control board	12	Heating element
3	Electrical box	13	Top cover
4	Four-way valve	14	Diversion air duct
5	Electronic expansion valve	15	Evaporator
6	Front shell	16	Support
7	Display panel and cover	17	DC motor
8	Control panel and screen	18	Fan blade
9	Compressor	19	Rear shell
10	Sensor pocket	20	Magnesium anodes

DESCRIPTION OF PARTS AND COMPONENTS (330L)

330L heat pump layout

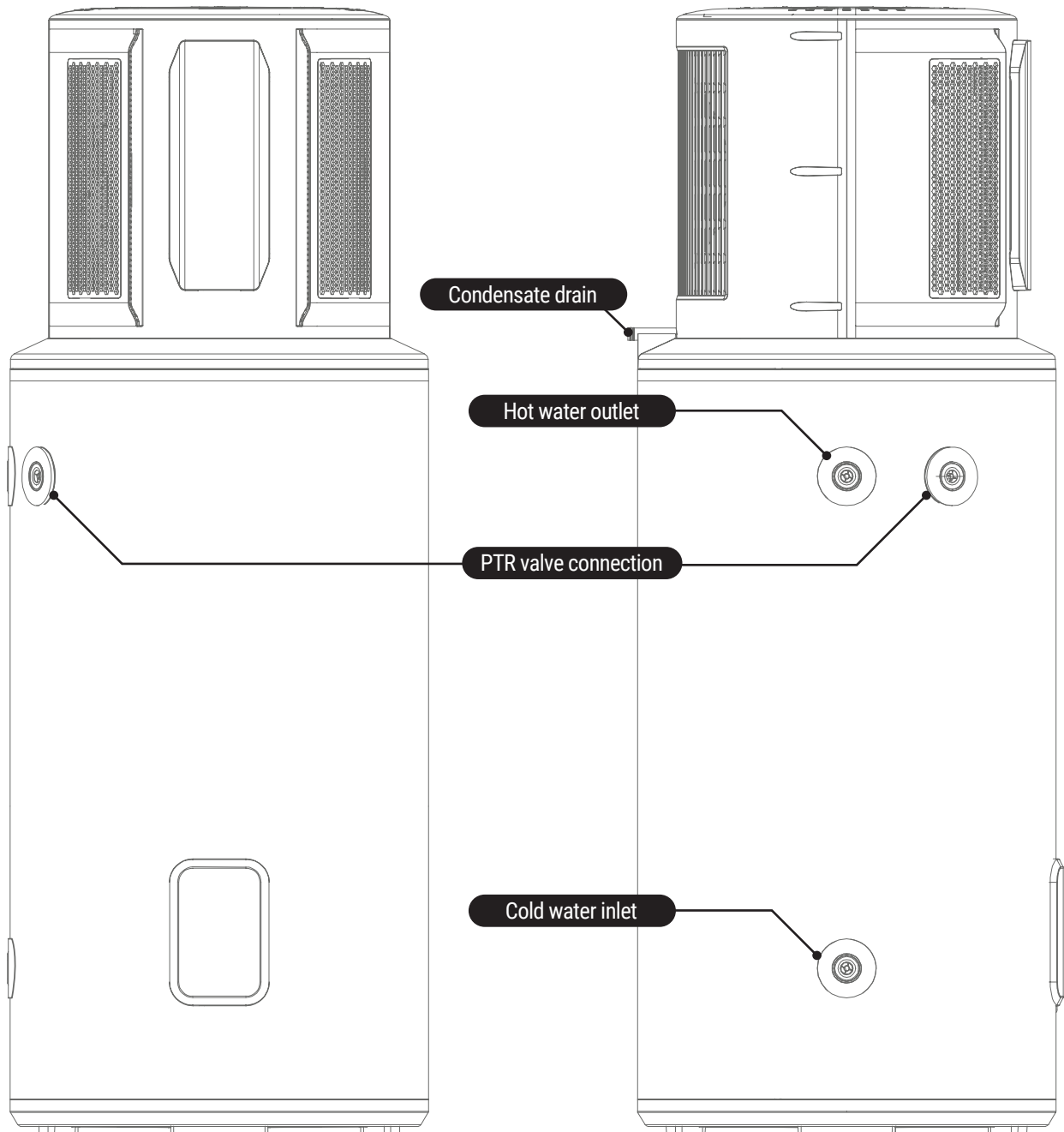

Carton contents

Part Name	Heat Pump Water Heater	Instruction Manual	PTR Valve
Quantity	1	1	1

Exploded view of the 330L heat pump

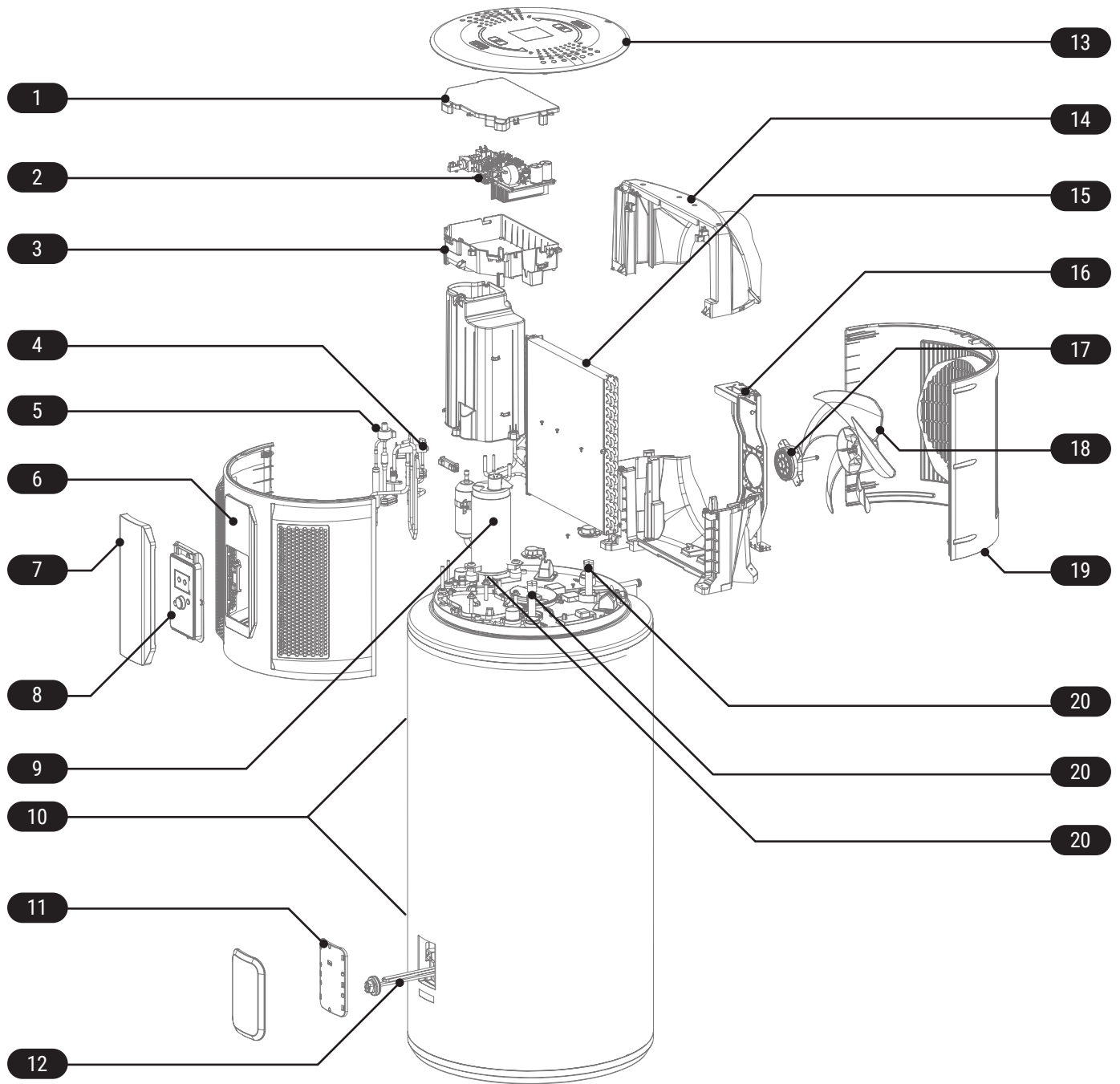

1	Electrical box cover	11	Waterproof cover
2	Electronic control board	12	Heating element
3	Electrical box	13	Top cover
4	Four-way valve	14	Diversion air duct
5	Electronic expansion valve	15	Evaporator
6	Front shell	16	Support
7	Display panel and cover	17	DC motor
8	Control panel and screen	18	Fan blade
9	Compressor	19	Rear shell
10	Sensor pocket	20	Magnesium anodes

PLUMBING INSTALLATION



WARNING

THIS APPLIANCE MAY DELIVER WATER AT HIGH TEMPERATURE. REFER TO THE PLUMBING CODE OF AUSTRALIA (PCA), LOCAL REQUIREMENTS AND INSTALLATION INSTRUCTIONS TO DETERMINE IF ADDITIONAL DELIVERY TEMPERATURE CONTROL IS REQUIRED.

This installation should only be performed by an approved professional with suitable experience and licenses, authorised by Energie Group Australia Pty Ltd to conduct the work.

1. The water heater must be installed:
 - a. by licensed trades people.
 - b. in accordance with all local codes and regulations and standards including AS/NZS3500.4, AS/NZS 3000, and the Plumbing Code of Australia (PCA).
2. The inlet water pressure of water supply must be between 100kPa – 500kPa.
3. Inlet water connections: An isolating and non-return valve must be installed on the inlet to the appliance. If the supply pressure could exceed 500kPa, a pressure limiting valve must be installed on the cold-water inlet. If a cold water expansion control valve (ECV) is required by local regulations, a valve of a maximum of 600kPa can be fitted. The correctly sized pressure limiting valve should also be fitted as per the ECV manufacturers specifications. If no ECV is fitted, a pressure limiting valve of a maximum of 500kPa should be fitted.
4. The cold-water inlet to the appliance must have a line filter, non-return valve and isolating valve fitted. Combination valves of these functions are also suitable.
5. Outlet water connections: A thermostatic mixing or tempering valve must be used when hot water is supplied to fixtures used for sanitary use (i.e. bathrooms) according to AS/NZS 3500.4 requirements.
6. For ease of assembly and disassembly of the appliance, it is recommended that mechanical joints are used to connect to the water heater.
7. The water inlet and outlet pipes must be fitted to as per the labels at the hot and cold-water connections.
8. To avoid damage to the appliance, the inlet water temperature should remain between 10-40°C.
9. Before filling the tank, make sure that the cold-water inlet and hot- water outlet of the appliance are open, along with the farthest hot water fixture are opened. The appliance will be correctly filled once water flows continuously from this fixture without air bubbles. Venting through the PTR could cause premature failure of the valve.
10. If there is a risk of freezing, hot and cold water pipes connected to the appliance must be insulated with 20mm insulation. Failure to adhere to this may result in a voided warranty if damage due to freezing occurs.
11. In accordance with safety rules, a PTR valve (700kPa, 99°C, Rp $\frac{3}{4}$ ") must be installed directly into the PTR valve connection on the appliance. Never block the outlet of the safety valve or its drain line for any reason.

Piping installation diagram

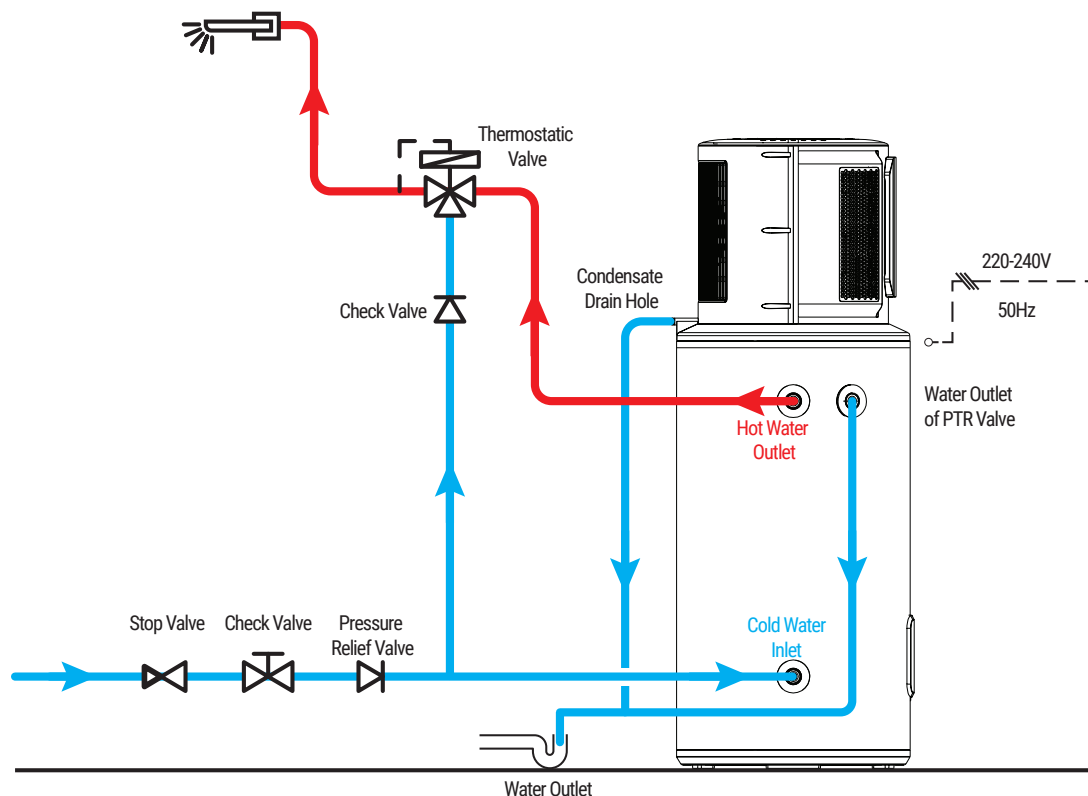

Seismic strapping

FOR NEW ZEALAND INSTALLS ONLY



The Plumbing & Drainage standard (AS/NZS 3500.4) requires all storage water heaters in New Zealand to be installed with seismic restraints to avoid damage or personal injury if a seismic event should occur.



To meet this requirement this appliance should be fitted with three stainless steel straps, 25mm wide x 1mm thick.

These straps should be fitted as per the following instructions:

- **Top strap:** Under the front cover, and no more than 100mm from the top the painted cylinder section of the appliance
- **Middle strap:** Under the front cover, at the center of the painted cylinder section of the appliance
- **Bottom strap:** Below the front cover, and no more than 100mm from the bottom the painted cylinder section of the appliance

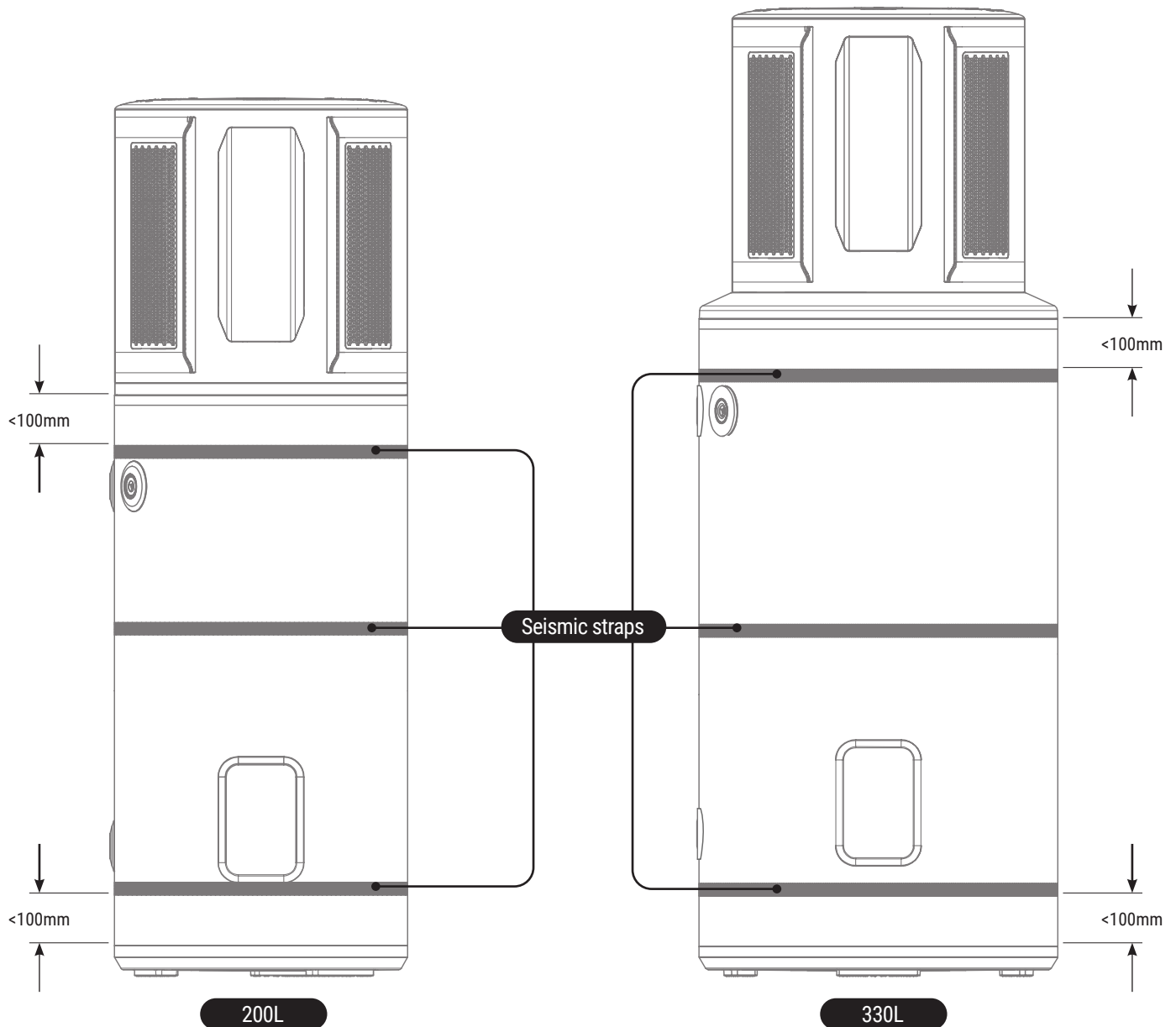

ELECTRICAL INSTALLATION



CAUTION

In order to avoid inadvertent resetting of the thermal cut-out, this appliance must not be supplied through an external switching device, such as a timer, or connected to a circuit that is regularly switched on and off by the utility (off-peak electrical line).

Electrical safety requirements

1. The installation, service or repair of the electrical components of this appliance must be completed:
 - a. by licensed trades people.
 - b. in accordance with all local codes and regulations and standards AS/NZS 3000.
2. The surrounding conditions (ambient temperature, direct sunlight and rainwater) shall be considered during electrical wiring, with effective protective measures taken to suit the environment.
3. Materials that are certified to local standards must be used in the installation of this appliance.
4. The appliance must be reliably earthed.
5. The appliance is equipped with a 10A plug and cord that enables connection to power via an RCD protected weatherproof power outlet on a common electrical circuit.

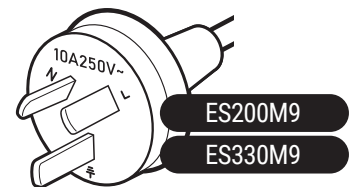

COMMISSIONING CHECK LIST

System location – ensure that

- The location where the base of the water heater is located is sufficiently compact to avoid subsidence when the system is filled with water.
- Enough room has been allowed for service and maintenance of the water heater.
- The system has been installed in a location that allows enough ventilation.
- The location is free from any corrosive materials or chemicals.
- The location is free from any excessive dust or material that can become airborne.

Water system piping

- Temperature and pressure relief valve (PTR) is properly installed with a discharge pipe plumbed to suitable drain.
- Check that all plumbing connections including piping, valves and fittings are properly installed and free of leaks.
- The system is completely filled with water and all air is drained from the tank and piping.
- The tempering valve has been installed per manufacturer's instructions and the output water temperature is in the range required by local authorities.
- The condensate drain line is installed and plumbed to suitable drain.
- All hot water lines are appropriately insulated and protected from UV degradation.

Electrical connections

- The water heater is connected to a supply that has a voltage between 220-240 VAC.
- All hard wiring complies with all local applicable codes and the requirements of this guide.
- The water heater and electrical supply are properly grounded.
- A Residual Current Device (RCD) has been installed.

OPERATION AND FUNCTIONS

Functions and protections

A. Electrical leakage protection

This appliance features an electricity leakage protection function.

B. Compressor protection

When switched on, the appliance will take approximately 3 minutes to start the compressor for heat pump heating.

C. Automatic defrosting function

The defrosting mode is automatically activated if the outdoor temperature is low and the compressor has run for some time.

D. Overload protection

The working load of the compressor will be high in warm ambient air temperatures. To meet hot water requirements and to lengthen appliance life, this product automatically adjusts the fan speed to ensure reliable operation of the compressor.

E. Anti-freezing function

The heat pump maintains a minimum temperature to avoid damage to the appliance caused by freezing.





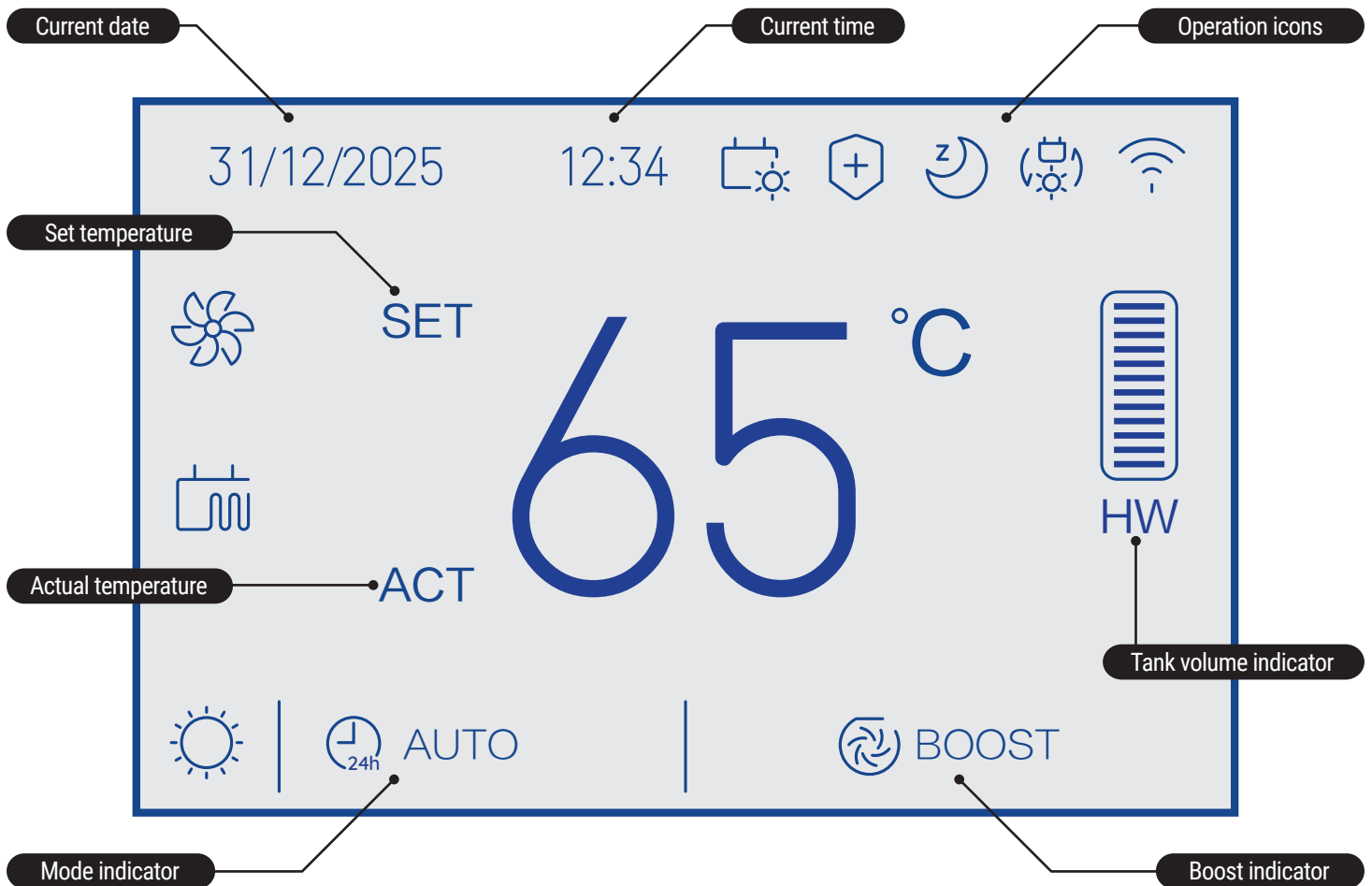

F. Default temperature

The default temperature setting is 60°C.

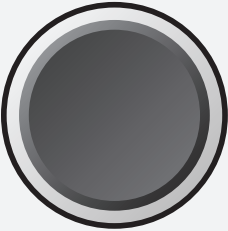
Display screen



Description of the icons

Symbol	Description
	<p>Rotary Dial In the OFF state, simply press the rotary dial to turn the machine on. Hold down the rotary dial for 6 seconds to power off the machine.</p>
	<p>Menu Button Enter the menu.</p>
	<p>Return Button Return to the last operation or screen.</p>
	<p>Child Lock In the child lock state, the mode, temperature and other settings cannot be performed. Double click the rotary dial to exit the child lock state, then you can set other functions.</p>
	<p>Boost Mode Heat pump and backup elements heat simultaneously for a faster recovery time. The heat pump stops and the electric heating starts. This function is effective once, heating to the set temperature, automatic exit.</p>
	<p>Working Mode Selection The AUTO / TIMER / ELEC / MUTE mode can be selected</p>

Symbol	Description
	<p>Automatic Mode</p> <p>This mode ensures optimal management of both the heat pump and backup element to deliver consistent comfort. You can adjust the compressor's maximum continuous working time (HP Duration) in the installer settings to suit your preferences.</p>
	<p>Timer Mode</p> <p>This mode prioritises heat pump heating. Users can input timer settings; however, if the set time starts and ends simultaneously, the function becomes invalid</p>
	<p>Electrical Heating Mode</p> <p>In this mode, the backup element serves as the sole heat source. This function guarantees hot water supply in instances where the heat pump is not functioning properly.</p>
	<p>Mute/night Mode</p> <p>During the designated mute time, the system operates with reduced noise levels. Please note that the system's performance may be adjusted during this period due to internal system changes.</p>
	<p>Standard Recovery Mode</p> <p>Standard operating program for maximum efficiency.</p>
	<p>Fast Recovery Mode</p> <p>This mode provides rapid hot water recovery, ideal for larger families.</p>
	<p>Heat Pump Operating Indicator</p> <p>This icon signifies that the heat pump is currently operational.</p>
	<p>Auxiliary Electrical Heater Indicator</p> <p>This icon signifies that the auxiliary electrical heating element is actively engaged, utilizing electrical energy to heat the water.</p>
	<p>Wi-Fi Function</p> <p>This icon signifies that wireless communication is in operation.</p>
	<p>Hot Water Volume Display</p> <p>This feature visually indicates the amount of water present in the tank, allowing users to easily monitor the current volume.</p>

Note: Under certain conditions, TIMER mode may result in shortages of hot water if the ambient air temperature is low.

Initial power on

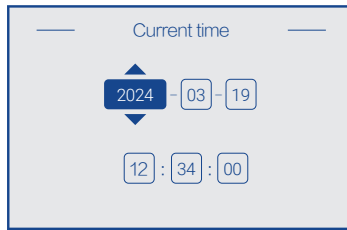

Figure 1

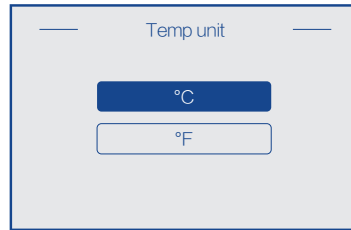

Figure 2

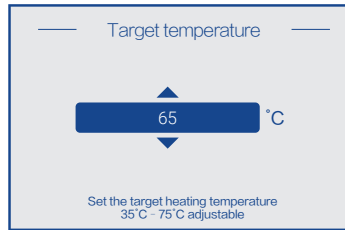

Figure 3

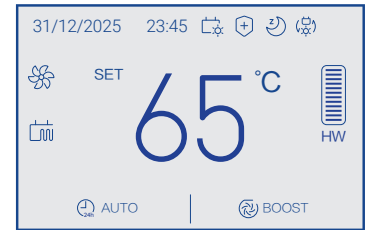

Figure 4

When the device is powered on for the first time, the screen lights up and enters startup mode. Begin setup by selecting the initial settings. Adjust the current time, set the temperature unit (°C/°F), and set the target temperature by turning the rotary dial. Press the rotary dial to confirm each selection. Set the temperature to 60°C (AUTO - Standard Recovery mode is set by default).

Subsequent power cycles will retain the previous settings unless the user chooses to restore the initial configuration.

Temperature setting

While on the interface depicted in Figure 3, users can adjust the temperature by turning the rotary dial clockwise or anti-clockwise. Settings will be automatically confirmed upon completion.

Screen lighting time

On the home screen (Figure 4), the display screen will turn off after 30 seconds of inactivity. Press any key to illuminate the screen again. If no operations are performed for 6 seconds on a non-home screen, the display will revert to the previous screen until the home screen is displayed.

Boost mode

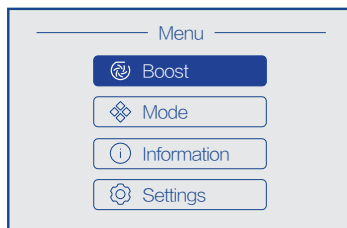

Figure 5

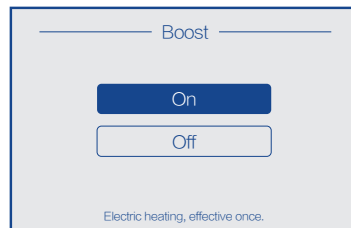

Figure 6

Click the Menu button to enter the Menu, select BOOST (Figure 5) by turning the rotary dial, click the rotary dial, select ON/OFF, and then click the rotary dial to confirm the function is on/off.

Auto mode

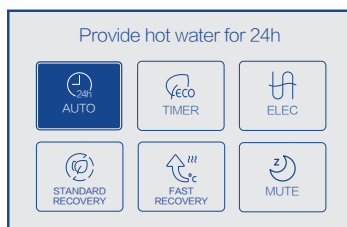

Figure 7

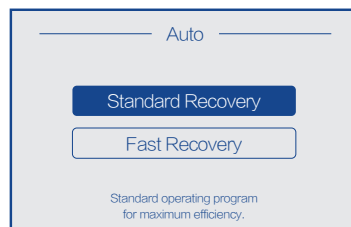

Figure 8

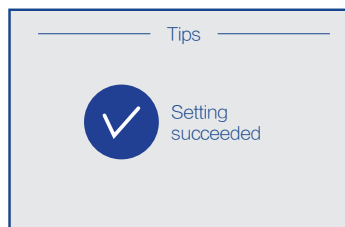

Figure 9

After selecting AUTO by pressing the rotary dial, press the rotary dial to select Standard Recovery, and then rotate the dial to select FAST RECOVERY. Press the rotary dial to confirm the setting.

Timer mode

Within the AUTO operation mode, select TIMER to access the TIMER program interface. Use the rotary dial to choose the heating schedule and click to confirm.

Same heating schedule

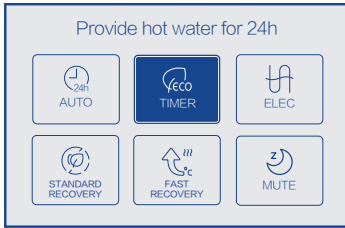

Figure 10

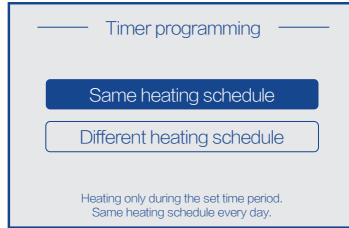

Figure 11

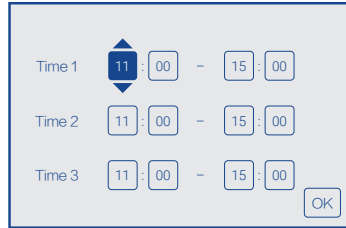

Figure 12



Figure 13

If “Same heating schedule” is selected, users can establish up to 3 distinct time periods (refer to Figure 12). During time setup, press the Back button to exit the time selection mode. Turn the rotary dial to adjust time values and click to re-enter the time selection mode. After successfully setting the time, set the heating mode. Time periods cannot span across nights. If the start and end times coincide, this function is disabled. The default setting is AUTO. After configuring the time, users must click OK to confirm, otherwise, the set time will not be saved.

Different heating schedule

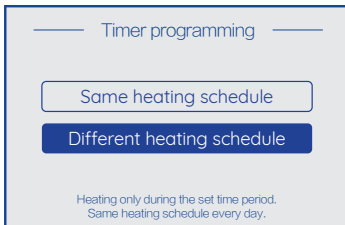

Figure 14

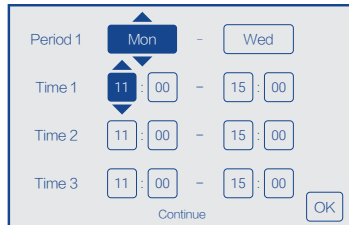

Figure 15

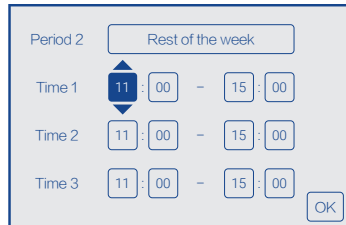

Figure 16

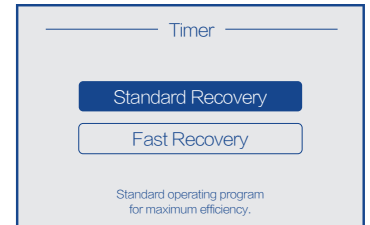

Figure 17

This mode operates similarly to “Same heating schedule,” but users can specify the day of the week and duration for heating. By default, the schedule starts on Monday (refer to Figure 15). After successfully setting the time, set the heating mode. Cross-week selection is not allowed. For instance, if Sunday is chosen as the start day, only Sunday can be selected as the end day.

Electric mode

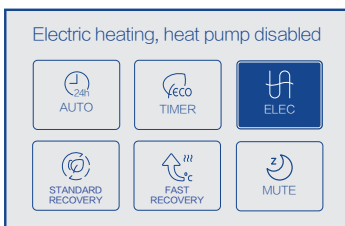

Figure 18

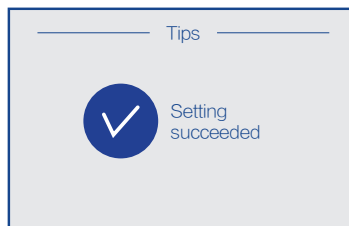

Figure 19

This mode functions identically to AUTO.

Mute mode

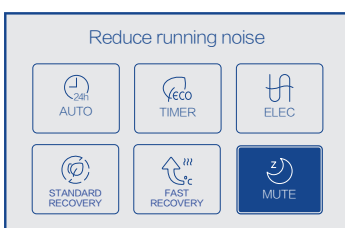

Figure 20

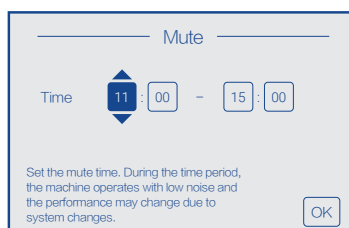

Figure 21

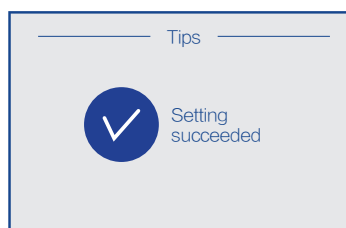

Figure 22

Within the AUTO operation mode, select MUTE to access the Mute interface. Users can set the time and duration on the next screen. Click OK to confirm the settings; otherwise, they will not be saved. When MUTE mode is activated, the mode indicator will become solid blue. To deactivate the function, click MUTE mode again. Mute cannot be activated simultaneously with the Fan Speed function.

Wi-Fi setup and smartphone app guide

Requirements: Bring your own smart phone and wireless router (internet connection required).

App download

Search for “Smart Life” in the Apple App Store or Google Play Store, or scan the provided QR code to download the app.



Account registration

After the app is installed, you'll need to create an account to use it. After launching the app, click on “Register” to register your account and log in.

Activate the Wi-Fi module

Power on the control panel. On the display, navigate to **Settings > Connect > Wi-Fi Factory Reset** to activate the Wi-Fi module (the Wi-Fi icon will flash).

App pairing steps

1. In the app, go to the device list and tap **Add Device**.
2. Choose **Large Household Appliances**, then select **Water Heater (BLE+WiFi)**.
3. Select your **2.4GHz** Wi-Fi network, enter the password, and tap **Next**.
4. Follow the on-screen instructions to complete device pairing.

MAINTENANCE

The heat pump water heater is designed so that there is little to do in the way of regular system maintenance.



WARNING

Personally inspecting or servicing any part of the system is not recommended.

Shut down the machine and cut off the power before any work commences.

Maintenance operations are important to guarantee optimum performance and extend the life of the appliance.

Draining and flushing the system



CAUTION

The system must be completely drained of water before any plumbing work is commenced. This will prevent damage to the storage tank in the event of a vacuum or excessive pressure forming at the storage tank.



The heat pump hot water system should be drained and flushed every five years during a major service of the unit.

1. Turn off and isolate the power supply to the electrical element.
2. Turn off the water supply to the water heater.
3. Release excess pressure from the tank by manually opening the pressure & temperature relief valve.
4. Disconnect the cold water supply pipe connection to the tank.
5. Fit a ½" flexible drain pipe to the cold connection at the tank. Place the open end of the drain hose in a location where it is safe for the hot water to drain away from the tank.
6. Manually open the pressure & temperature relief valve which will allow air into the tank and the water within the tank will flow out via the flexible drain pipe fitted to the cold inlet connection. Hold the valve open until the tank is empty.

Relief valves



The lever on the relief valves should be operated at least every six months. Failure to do so may result in failure of the tank. If water does not discharge freely from the valves they should be checked and possibly replaced. The relief valves and relief valve drain lines must not be blocked. Some water may discharge during each heating cycle.

Every five years all safety valves should be replaced to ensure the continued life and operational safety of the system. In locations where the potable water has a Total Dissolved Solids (TDS) of greater than 600ppm it is recommended to replace all safety valves every three years.

Condensate discharge pipe



Check the pipe regularly for cleanliness. Any obstruction may cause poor condensate flow or cause the accumulation of water in the heat pump plastic base.

Anode replacement



The high quality vitreous enamel lined, low carbon steel tank has three sacrificial anodes for long tank life. These anodes should be inspected every few years and replaced when they have worn out.

As a minimum it is recommended that the anodes be changed *every five years*.

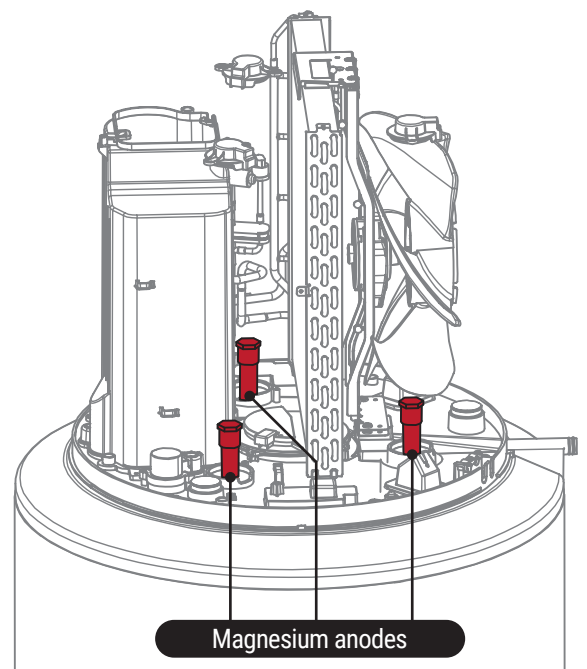

Water quality

Water supply from an unfiltered water source that may be highly conductive or have a high mineral content may void the system warranty. The following characteristics should not be exceeded in order for the warranty to be conditions not to be breached.

Water Properties	Acceptable Levels
Total hardness	200 mg/litre or ppm
Total Dissolved Solids (TDS)	600 mg/litre or ppm 250 mg/litre or ppm
Chloride	10 mg/litre or ppm 150 mg/litre or ppm
Magnesium	Min 6.5 to Max 8.5
Sodium	850 µS/cm
pH	Min 6.5 to Max 8.5
Electrical conductivity	850 µS/cm



WARNING

A breach of this condition may void the warranty in the event of damage caused by water quality exceeding these characteristics.

TROUBLESHOOTING

If there is not enough hot water we recommend that the following points are considered as part of the service call. The most obvious reasons for a lack of hot water could be one of the following.

Hot water use higher than anticipated

Often the hot water usage of showers, washing machines and dishwashers is underestimated by the customer. Review these appliances to determine if the daily usage is greater than the storage volume of the water heater. Depending on the model of your system, your tank contains a volume of either 200 or 330L of hot water. If the demand exceeds the stored volume, there may be periods where the water temperature is slightly lower than normal. It is also advisable to inspect hot water tap washers etc. for leakage and replace if necessary.

Water discharge through the pressure relief valve

All heat pump water heaters have two pressure valves located within the system configuration. The cold water expansion control valve (ECV), located in the cold water supply pipe, may release a small amount of water from time to time during the heating cycle of the system. The water discharge is water expanding due to the heating process. Normally the discharge will be less than 10 litres per day. The pressure & temperature valve, located on the storage tank, may also release a small expansion discharge.

It is normal for the Expansion Control Valve (ECV) to drip water when heating. If there is a discharge of more than 10 litres per day from any of the systems valves, it indicates there may be a problem with the valve or an increased water supply pressure. Contact your authorised Envirosun dealer or installation service provider as soon as possible.

FAULTS AND PROTECTION

Code	Fault Type	Description	Resolution
F2	Compressor	Operating temperature protection.	Please call Envirosun to resolve the issue.
F3		Air exhaust temperature protection.	
F5		Evaporation high temperature protection.	
F6	Compressor over-current	Over-current protection.	
E1	Electricity leakage alarm	The system will automatically cut power if any line fault occurs.	
E2	Over temperature alarm	The actual water temperature $\geq 85^{\circ}\text{C}$.	
E3	Inner temperature sensor	If short circuit or circuit break occurs to the sensor.	
E4	Ambient temperature sensor		
E5	Evaporation temperature sensor		
E6	Air exhaust temperature sensor		
ED	Air intake temperature sensor		
E7	Communication fault	Abnormal communication between main control and display panel.	
E8	Pressure switch protection	Action of the pressure switch at the exhaust outlet.	
E9	Ambient temperature protection	Ambient or outdoor temperature $< -7^{\circ}\text{C}$ or $> 45^{\circ}\text{C}$.	
EF	Off-peak power switching signal	If not received the off-peak signal when selecting switch signals by power companies.	
L7	Fan	Fan blade is stuck or fan and control panel communication failure.	
P1	Transient hardware overcurrent of the compressor phase current	The MCU detects a low level input at the F0 port or a bus current greater than the 19.4A peak threshold set by the MCU internal comparator	Power on or off the device again. The fault is rectified
P2	Compressor phase current software transient overcurrent	The instantaneous output current is greater than 17A	When the current is less than the set protection value, the system automatically recovers after 20 seconds
P3	The heat sink (IPM) temperature is too high	IPM module temperature $> 100^{\circ}\text{C}$	60 seconds later, the MCU detects that the IPM module temperature is lower than 85°C and automatically recovers
P4	Input overflow load	The input current RMS exceeds 18A or the peak output current exceeds 17A	The compressor automatically recovers after shutdown
P5	Undervoltage protection	Bus voltage below 200V lasts for 5ms	If the VDC is greater than or equal to 210V after the compressor is stopped for 20 seconds, the fault is rectified
P6	Over Voltage Protection	PFC voltage or bus voltage VDC greater than 390V for 5ms	After the compressor is stopped for 20 seconds, the fault is rectified if the $\text{VDC} \leq 380\text{V}$
P7	The communication between the main control chip and the driver chip is abnormal	The master control and driver cannot receive data or a data error persists for 2 minutes	After receiving the communication from the other party, it automatically recovers and the fault is eliminated
P8	The current detection on the frequency conversion side is abnormal	Before the compressor is in operation, there is a 10-20% deviation between the AD value of the incoming voltage detected by the sampling circuit and the AD value of 1.65V	The circuit is repaired and then powered on again
PB	Compressor out of step	The actual running speed of the compressor is less than 50% or more than 120% of the target speed of the drive for more than 5S	Detect normal fault elimination
PD	Instantaneous Software Overflow on the rectifier side	The instantaneous value of the input current is greater than 30A for 3 times, and each PWM cycle is detected once	After the compressor is stopped for 20 seconds, the current is less than 30A and automatically recovers. Power off and restart. The fault is rectified
PF	Transient hardware overcurrent on the rectifier side	The instantaneous input current is greater than 31A for four times	The compressor automatically recovers when the current is less than 31A after 20 seconds of shutdown. Power off and restart. The fault is rectified



This symbol on the product or on its packaging indicates that this product is not to be treated as regular household waste. It must be taken to a recycling collection point for electronic equipment.

By properly disposing of this product, you are contributing to the preservation of the environment and the wellbeing of your fellow citizens. Improper disposal is hazardous to health and environment.

You can obtain further information on how to dispose of this product correctly by calling Envirosun.

STANDARD WARRANTY

Warranty terms

This warranty is given by Energie Group Australia Pty Ltd in relation to Envirosun Heat Pump Hot Water Systems (the Product).

The benefits conferred by this warranty are in addition to all other legal rights and remedies of the Customer in respect of the Product. Given installation and application is in accordance with the manufacturer's specifications and instructions, the Product and components are warranted by Envirosun for the cost of labour and components in the event of defects arising from faulty materials and/or workmanship in accordance with the warranty conditions and exclusions stated in this document.

Where the Product is installed outside the boundaries of a Capital City Metropolitan area or where the Product is installed outside a 25km radius of a Envirosun Dealer business address, the cost of transport, insurance and travelling will be charged to the consumer.

For all new Product purchases through public sales auctions, internet and/or other electronic sales auctions or remote offerings, the warranty for the Product is the responsibility of the dealer or reseller of the Product, and not of Envirosun.

Warranty of the Product will remain with the Product for the warranty coverage period.

Warranty conditions

The initial point of contact for all Warranty claims is the Envirosun Dealer from whom the Product was purchased.

All warranty claims must be reported to Envirosun no later than 14 days from the date the fault is reported to the Envirosun Dealer. All terms of this warranty are effective from the date of installation of the Product and the attending service person reserves the right to verify this date by requesting a copy of the certificate of compliance¹, installation record issued by an appropriately qualified installer or proof of purchase prior to the commencement of any warranty work.

The Product must have been installed, commissioned, serviced, repaired and removed by a licensed gasfitter or plumber in accordance with the manufacturer's installation instructions, current AS/NZS 3000, AS/NZS 3500, AS/NZS 5601, local regulations and municipal building codes by persons authorised by local regulations to do so. Cost of labour or materials to remedy an installation that does not comply with these requirements will be at the express cost of the installer.

The Product must be operated and maintained in accordance with Envirosun's operating instructions. This warranty only applies to the Product as supplied by Envirosun and does not apply to any additional electrical and/or plumbing parts supplied by the installer. Where the appliance has not been sited in accordance the installation instructions or installed such that normal service access is difficult, a service charge may apply. If, at the discretion of the attending service person, access with is assessed as dangerous, service will be refused.

Any work required to gain reasonable access to the appliance will be chargeable to the customer by the attending service person including, but not limited to, removal of cupboards, doors, walls, or the use of special equipment to move components to floor level.

The Product is covered for the indicated period from the date of installation. Should a part of the complete Product be replaced during this period, only the balance of the original warranty will continue to remain effective.

This warranty applies to the Product when it is connected directly to a reticulated water supply from a state approved water utility.

This warranty does not apply if the Product is connected to any alternative water supplies if the water chemistry and impurity levels of alternative water supplies exceed the limits specified in the Water Properties Table on page 23.

Examples of alternative water supplies include private bore water, water from private dams and water supplied from a reticulated water supply but where the water chemistry is deliberately altered before supplying the water heater. Should the Product be installed in a regional location where regular flushing is required due to sediment build-up, the drain cock for flushing must be fitted at the time of installation at customer expense. A warranty will apply to rain water tanks, as alternative water supply, ONLY in circumstances where rain water is filtered and free of any physical or sediment debris and water quality does not exceed the limits specified in the Water Properties Table on page 23.

Component manufacturers are at liberty to alter the design or construction of the components notwithstanding that the Product may have been sold by description or sample, even though alterations made have been introduced from the date of contract and the date of delivery provided that the Products are of the same or similar quality and are fit for the purposes for which they are purchased. Such alterations shall not constitute a defect in design or construction under this warranty.

Envirosun reserves the right to alter the design or construction of the Product within allowance of the relevant Standard(s), industrial and State and Territory legislation without notice. Envirosun warrants to the original purchaser, or for Product purchased from a Reseller, to the original end user, that the Product will be free from any defects in materials and workmanship from the date of shipment or invoice or, if longer, the period stated in this policy in accordance with the Warranty Coverage table on page 26.

During the warranty period, Envirosun will, at its option, apply one of the three following remedies:

- i. provide replacement parts necessary to repair the Product,
- ii. replace the Product with same Product or similar approved newer design,
- iii. refund the amount purchaser paid, LESS DEPRECIATION, upon its return.

Envirosun or a Envirosun Dealer will provide labour to resolve warranty issues during the warranty period. Repair service shall be available at the purchaser's location. Envirosun will determine how and where repair services are provided, and the purchaser may, at Envirosun's reasonable cost, be required to deliver product to an authorised location.

Replacement parts and/or Products will be new or serviceably used, comparable in function and performance to the original part or Product and warranted for the remainder of the original warranty period. Purchasing additional Products from Envirosun does not extend your warranty period.

If Envirosun requires the return of defective parts/Products, the Envirosun Dealer/purchaser shall return them within 14 days of receiving replacement parts. Failure to return defective parts will attract charges for replaced parts/system and their shipment to the Envirosun Dealer/purchaser.

Envirosun offers the following Warranty Coverage on all models:

Component	Warranty Coverage	
	Parts Warranty	Labour Warranty
Tank Cylinder*1	7 year	2 year
Compressor	5 year	2 year
Electrical components	5 year	2 year
PTR valve and ECV	1 year	1 year
Installer supplied valves and fittings	N/A	N/A

*1 conditional after 5 years that all anodes, PTR and ECV valves have been replaced prior to 5 years from installation.

NOTE: Without limiting the periods shown in the table, a 5-year whole-of-product warranty applies where a rebate has been received under Solar Victoria's Solar Homes Program for a water heater installed from 1 JULY 2023. Proof of receipt of the rebate is required to be produced at the time of the service call.

Warranty exclusions

The following exclusions may cause the warranty to become void, and may incur a service charge and cost of parts that may be required.

1. Accidental damage, failure due to misuse, abuse and accidents.
2. Failure due to incorrect installation and/or attempts to repair the Product other than by an Envirosun Dealer or approved service personnel.
3. Failure to install, commission, service, repair and remove the Product in accordance with the manufacturer's installation instructions, current AS/NZS 3000, AS/NZS 3500, AS/NZS 5601, local regulations and municipal building codes by persons authorised to do so.
4. Failure due to use of parts other than Envirosun branded/approved parts.
5. Where the tank or piping system leaks or fails to operate normally due to frost or freezing.
6. Where the Product component has failed directly or indirectly as a result of excessive water pressure, negative pressure (partial vacuum), corrosive atmosphere, faulty plumbing and/or electrical wiring, or major variations in electrical energy supply.
7. Where the water stored in the cylinder exceeds at any time levels as detailed in this document.
8. Any serial tags/stickers on any of the components are removed or defaced.
9. The Product is relocated from its original point of installation.
10. This warranty does not cover:
 - a. claim for damage to walls, foundations, gardens, etc. or any other consequential loss or inconvenience either directly or indirectly due to leakage from the water heating system or any other matter related to the system or its operation.
 - b. the effects of sludge/sediment as a result of connection to a water supply from suitably filtered or treated sources e.g. spring, dam, bore or river.
11. Consequential damage or any incident caused by a breach of the requirements as set out in this document.
12. Our goods come with guarantees that cannot be excluded under the Australian Consumer Law. You are entitled to a replacement or refund for a major failure and for compensation for any other reasonably foreseeable loss or damage. You are also entitled to have the goods repaired or replaced if the goods fail to be of acceptable quality and the failure does not amount to a major failure.

OH&S Disclaimer

Envirosun and its Authorised Dealers work with and recommend various installation and plumbing companies to install, test and certify correct operation of solar hot water systems or the Product. Envirosun is a supplier of systems only.

Each installation must be covered by the installer's insurances, commercial terms and conditions and by the applicable OH&S legislation. Each person that installs assembles or services must comply with all OH&S requirements relevant to the type of work being conducted including, but not limited to, plumbing work, work on heights exceeding 2.5m and electrical work.

The customer must ensure that it complies with all its OH&S obligations. This warranty will be void if these conditions are not met.

CONTACT DETAILS

For further information, please call one of the following phone numbers from anywhere in Australia:

Energie Group Australia Pty Ltd	For after sales service:	1300 825 143
	For sales or new product:	1300 314 173 sales@ega.energy www.energiegroup.au

Head Office	Energie Group Australia Pty Ltd 460 Victoria Road Malaga WA 6090
--------------------	--

