

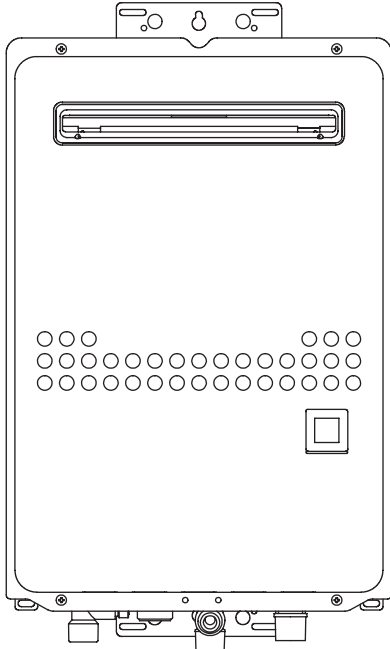

Installation Manual



(e.g. 26ENG5N)

Non Condensing Models

26ENG5N
26ENG5L
26ENG6N
26ENG6L
21ENG5N
21ENG5L
21ENG6N
21ENG6L
17ENG5N
17ENG5L
17ENG6N
17ENG6L

⚠ WARNING

FOR CONTINUED SAFETY OF THIS APPLIANCE IT MUST BE INSTALLED, OPERATED AND MAINTAINED IN ACCORDANCE WITH THE MANUFACTURER'S INSTRUCTIONS.

To be installed and serviced only by an authorised person.

This appliance is not suitable for use as a pool heater.

The "authorised installer" is responsible for:

1. Correct commissioning of this appliance
2. Ensure unit performs to the specification stated on the data label
3. Demonstrate operation of the unit to the customer before leaving
4. Hand these instructions to the customer

This appliance must be installed in accordance with the manufacturer's installation instructions and Plumbing Code of Australia (PCA) and all Local Building, Water and Gas fitting regulations (AS/NZS 5601, AS/NZS 3000, AS/NZS 3500.4).

Failure to install this appliance in accordance with these installation instructions may void warranty.

In the interest of continued product improvement, the manufacturer reserves the right to alter these specifications without notice.



Potential dangers from accidents during installation and use are divided into the following four categories. Closely observe these warnings, they are critical to your safety.

⚠ DANGER

Indicates an imminently hazardous situation which, if not avoided, will result in death or serious injury.

⚠ WARNING

Indicates a potentially hazardous situation which, if not avoided, could result in death or serious injury.

⚠ CAUTION

Indicates a potentially hazardous situation which, if not avoided, may result in minor or moderate injury.

NOTICE

Indicates a potentially hazardous situation which, if not avoided, may result in property damage.

⚠ WARNING

If the information in this manual is not followed exactly, a fire or explosion may result causing property damage, personal injury or death.

⚠ CAUTION**Requests to Installers**

- In order to use the Water Heater safely, read this installation manual carefully, and follow the installation instructions.
 - Failures and damage caused by erroneous work or work not as instructed in this manual are not covered by the warranty.
 - Check that the installation was done properly in accordance with this Installation Manual upon completion.
 - After completing installation, either place this Installation Manual in a plastic pouch and attach it to the side of the Water Heater (or the inside of the pipe cover or recess box if applicable), or hand it to the customer to retain for future reference. Also, be sure to fill in all of the required items on the warranty and to hand the warranty to the customer along with the Owner's Guide.
-
- The Water Heater must be commissioned including checking gas supply pressures at maximum demand.
 - The operation of the Water Heater should be explained including normal operation and regular maintenance.



Contents

1.	Before Installation	4
2.	About the Water Heater	5
3.	Choosing an Installation Location	11
4.	Installation Clearances	12
5.	Installation of the Water Heater	13
6.	Connecting the Gas Supply	14
7.	Connecting the Water Supply	19
8.	Connecting Electricity	21
9.	Remote Controller	22
10.	Trial Operation	25
11.	Maintenance	27

1. Before Installation

⚠ WARNING

Check the Gas

- Check that the data label (left side of casing).
- Check that the gas supply pipe is sized for
 26ENG5(6)N: 195 MJ/hr
 26ENG5(6)L: 195 MJ/hr
 21ENG5(6)N: 159 MJ/hr
 21ENG5(6)L: 159 MJ/hr
 17ENG5(6)N: 125.5 MJ/hr
 17ENG5(6)L: 127 MJ/hr
- DO NOT OPERATE WITH ANY OTHER GAS TYPE.

(For NG Gas)

MODEL XXXXXXXX		
GAS TYPE	: NG	
GAS CONSUMPTION	: xx MJ/hr	
HEAT OUTPUT	: xx kW	
ELECTRICAL RATING	: AC230-240V 50Hz	
RATED POWER	: xx W	
HOT WATER SUPPLY CAPACITY	: XXL/min RAISED XX°C	
GAS PRESSURE TEST POINT		

Check the Power

The power supply required is 230- 240 VAC, at 50 Hz.

Using the incorrect voltage may result in fire or electric shock.

Warning labels

Located on the front and left hand side of the casing-PLEASE READ THESE LABELS CAREFULLY!

If the appliance delivers water in excess of 50 Degrees, the following warning must be adhered to:

THIS APPLIANCE MAY DELIVER WATER AT HIGH TEMPERATURE. REFER TO THE PLUMBING CODE OF AUSTRALIA (PCA), LOCAL REQUIREMENTS AND INSTALLATION INSTRUCTIONS TO DETERMINE IF ADDITIONAL DELIVERY TEMPERATURE CONTROL IS REQUIRED.

If the appliance is a 50 degree locked model, the following statement & warning must be adhered to:

THIS APPLIANCE DELIVERS WATER NOT EXCEEDING 50°C IN ACCORDANCE WITH AS 3498.

WARNING — THIS APPLIANCE MUST ONLY BE INSTALLED IN ACCORDANCE WITH THE ACCEPTABLE PLUMBING CONFIGURATIONS SPECIFIED IN THESE INSTRUCTIONS. FAILURE TO DO SO MAY RESULT IN CONDITIONS WHERE DELIVERY TEMPERATURE CONTROL IS INADEQUATE.

⚠ CAUTION

Do Not Use Appliance for Purposes Other Than Those Specified

Do not use for other than increasing the temperature of the water supply, as unexpected accidents may occur as a result.

Check Water Supply Quality

If the water supply is hard, acidic or otherwise impure, treat the water with approved methods in order to ensure full warranty coverage. See water quality statement on page 27.

Frost Protection

When installed, power to the appliance must be kept switched on, otherwise the appliance should be drained. This prevents water freezing, and causing damage to the Water Heater.

NOTICE

- This appliance is suitable for potable water applications.
- Do not use this appliance if any part has been underwater. Immediately call a qualified service technician to inspect the appliance and replace any part of the control system and gas control which has been under water.

2. About the Water Heater

2.1 Included Accessories

The following accessories are included with the Water Heater.
Check for any missing items before starting installation.

Anchoring Screw (x 5)



Owner's Guide,
Installation Manual (this document) (1 each)

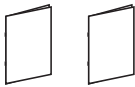

2.2 Specifications

- Specifications may be changed without prior notice.
- The capacity may differ slightly, depending on the water pressure, water supply, piping conditions, and water temperature.

Item		Specification					
Model Name	50°C model	26ENG5N	26ENG5L	21ENG5N	21ENG5L	17ENG5N	17ENG5L
	55°C model	26ENG6N	26ENG6L	21ENG6N	21ENG6L	17ENG6N	17ENG6L
Type	Installation	Outdoor, Wall mounted					
	Air Supply / Exhaust	Power Flue					
Operating Water Pressure		200-1,000 kPa					
Minimum Flow Rate		1.5 L/min					
Dimensions (Height) × (Width) × (Depth)		520 mm × 350 mm × 170 mm					
Weight		16 kg		15 kg		14 kg	
Water Holding Capacity		0.7 L				0.5 L	
Connection Sizes	Water Inlet	R 3/4 (20 mm)					
	Hot Water Outlet	R 3/4 (20 mm)					
	Gas Inlet	R 3/4 (20 mm)					
Power Supply	Supply	230- 240 VAC (50 Hz)					
	Consumption	NG/ULPG	55.0 W / 60.0 W		36.0 W / 49.0 W		31.0 W / 41.0 W
		Freeze Prevention	106 W				
Burner Injector Size	NG	1.45 mm / 2.1 mm		1.2 mm / 2.0 mm		1.2 mm / 1.8 mm	
	ULPG	1.0 mm / 1.4 mm		0.9 mm / 1.4 mm			
Accessories		Anchoring Screws					

Performances

Item		Maximum Performance					
Model Name	50°C model	26ENG5N	26ENG5L	21ENG5N	21ENG5L	17ENG5N	17ENG5L
	55°C model	26ENG6N	26ENG6L	21ENG6N	21ENG6L	17ENG6N	17ENG6L
Gas Consumption	NG	195 MJ/hr		159 MJ/hr		125.5 MJ/hr	
	ULPG	195 MJ/hr		159 MJ/hr		127 MJ/hr	
Maximum Hot Water Capacity (25°C Rise)		26 L/min		21 L/min		17 L/min	

2.3 Dimensions

26ENG series

< Unit: mm >

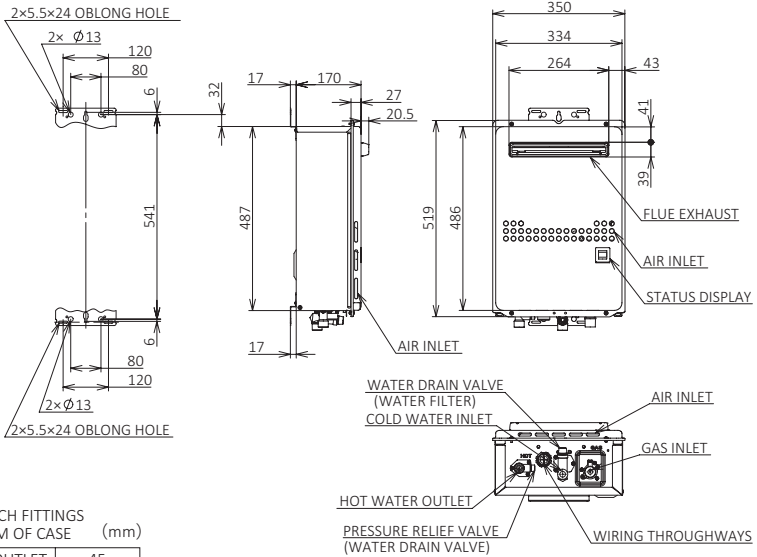
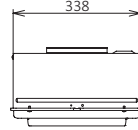
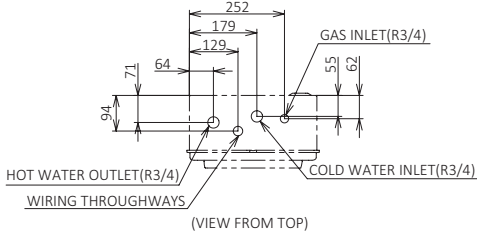

HEIGHT OF EACH FITTINGS
FROM BOTTOM OF CASE (mm)

HOT WATER OUTLET	45
COLD WATER INLET	53
GAS INLET	44

17/21ENG series

< Unit: mm >

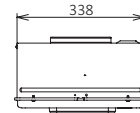
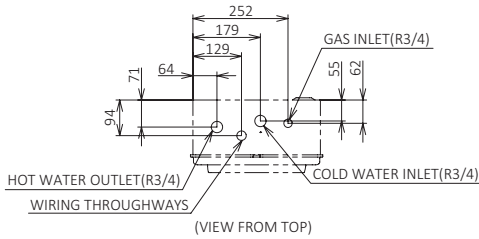
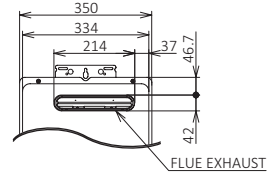
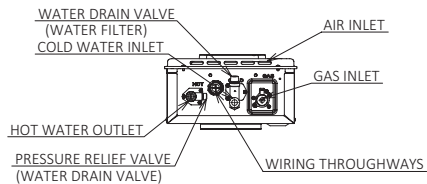
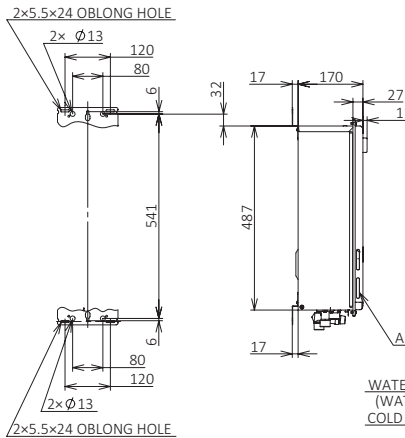
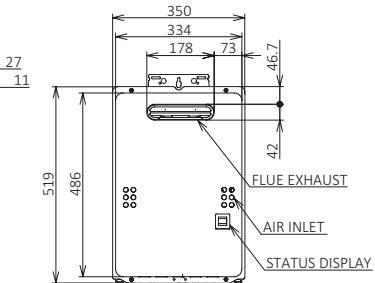
21ENG Series

17ENG Series

 HEIGHT OF EACH FITTINGS
 FROM BOTTOM OF CASE (mm)

HOT WATER OUTLET	45
COLD WATER INLET	53
GAS INLET	44

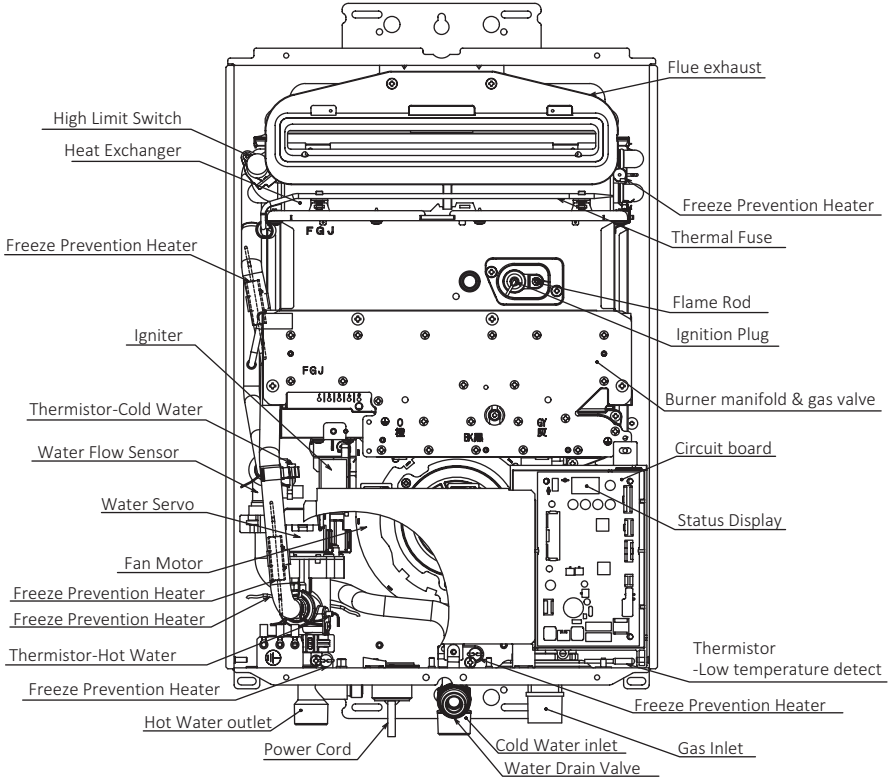
2.4 Component Details Example

26ENG series

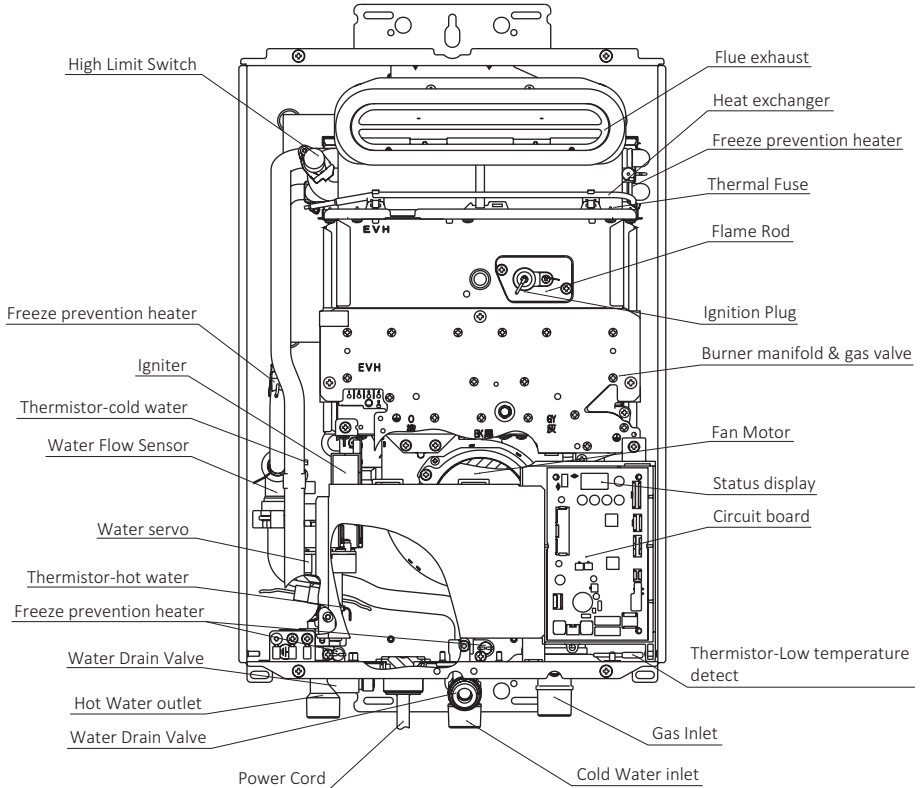

(e.g. 26ENG5N)

17/21ENG series

(e.g. 21ENG5N)

3. Choosing an Installation Location

⚠ DANGER

- This Water Heater is for outdoor installation only. Do not install indoors.
- Do not enclose the exhaust flue with corrugated metal or other materials. This may cause carbon monoxide poisoning and a potential fire hazard.

⚠ WARNING

- Avoid places where fires are common, such as those where petrol, benzene and adhesives are handled, or places in which corrosive gases (ammonia, chlorine, sulfur, ethylene compounds, acids) are present. If you do not follow the above, a fire or explosion may result causing property damage, personal injury or death.
- Avoid installation in places where dust or debris will accumulate. Dust may block the air-supply opening, causing the performance of the device fan to drop and incomplete combustion to occur as a result.
- Avoid installation in places where special chemical agents (e.g. hair spray or spray detergent) are used. Ignition failures and malfunctions may occur as a result.
- Do not install this Water Heater in a mobile home, recreational vehicle or on a boat as this may be a Carbon Monoxide Poisoning Hazard.

⚠ CAUTION

Do not install in the following places

- A location where it is not free from obstacles and stagnant air.
- Near staircases or emergency exits.

⚠ CAUTION

Consideration to the surroundings

- Do not install the Water Heater where the exhaust will blow on outer walls, other walls or material not resistant to heat. Also consider the surrounding environment. The heat and moisture from the Water Heater may cause discoloration of walls and resinous materials, or corrosion of aluminium materials.
- Do not locate the vent termination directed towards a window or any other structure which has glass or wired glass facing the termination.
- Take care that noise and exhaust gas will not affect neighbors.
- On combustible surfaces (e.g. weatherboards), it is not required to install a fire proof back board.
- Install in a location where the exhaust gas flow will not be affected by fans or range hoods.

**NOT
CORRECT**



Install according to regulations and manual

- The Water Heater must be installed according to the manual.
- Before installing, make sure that the exhaust flue will have the proper clearances according to AS/NZS 5601, or your local authority.

NOTICE

Locate the appliance in an area where water leakage from the unit or connections will not result in damage to the area adjacent to the appliance or to the lower floors of the structure. When such locations cannot be avoided, it is recommended that a suitable drain pan, adequately drained, be installed under the appliance. The pan must not restrict combustion air flow.

4. Installation Clearances

⚠ WARNING

Before installing, check for the following:

The location of the flue terminal must comply with the clearances shown on this page. If you are unsure about clearances not indicated here, in general refer to AS/NZS 5601, or your local authority. In Western Australia refer to the WA Office of Energy rules and regulations.

Flue outlet must be free from any combustible material.

CLEARANCES FOR FLUE TERMINAL (front of heater)

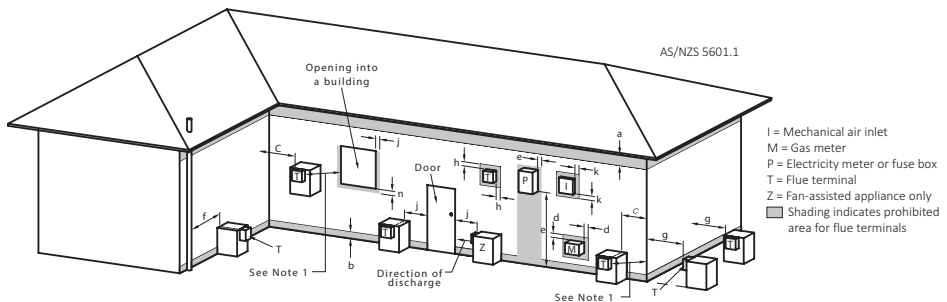

FIGURE 6.2 (in part)
LOCATION OF FLUE TERMINALS OF BALANCED FLUE, ROOM-SEALED, FAN-ASSISTED OR OUTDOOR APPLIANCES

Ref.	Item	Minimum clearances
		mm
		Fan assisted
a	Below eaves, balconies and other projections: Appliances up to 50 MJ/h input	200
	Appliances over 50 MJ/h input	300
b	From the ground, above a balcony or other surface *	300
c	From a return wall or external corner *	300
d	From a gas meter (M) (see Note 5) (see Clause 5.11.5.9 for vent terminal location of regulator) (see Table 6.7 for New Zealand requirements)	1000
e	From an electricity meter or fuse box (P) † (see Note 5)	500
f	From a drain pipe or soil pipe	75
g	Horizontally from any building structure * or obstruction facing a terminal	500
h	From any other flue terminal, cowl, or combustion air intake *	300
j	Horizontally from an openable window, door, non-mechanical air inlet, or any other opening into a building with the exception of sub-floor ventilation: Appliances up to 150 MJ/h input*	300
	Appliances over 150 MJ/h input up to 200 MJ/h input*	300
	Appliances over 200 MJ/h input up to 250 MJ/h input*	500
	Appliances over 250 MJ/h input*	1500
	All fan-assisted flue appliances, in the direction of discharge	1500
k	From a mechanical air inlet, including a spa blower	1000
n	Vertically below an openable window, non-mechanical air inlet, or any other opening into a building with the exception of sub-floor ventilation: Space heaters up to 50 MJ/h input	150
	Other appliances up to 50 MJ/h input	500
	Appliances over 50 MJ/h input and up to 150 MJ/h input	1000
	Appliances over 150 MJ/h input	1500

* Unless appliance is certified for closer installation.

† Prohibited area below electricity meter or fuse box extends to ground level.

NOTES:

- Where dimensions c, j or k cannot be achieved an equivalent horizontal distance measured diagonally from the nearest discharge point of the terminal to the opening may be deemed by the Technical Regulator to comply.
- See Clause 6.9.4 for restrictions on a flue terminal under a covered area.
- See Figure J3 for clearances required from a flue terminal to an LP Gas cylinder. A flue terminal is considered to be a source of ignition.
- For appliances not addressed above acceptance should be obtained from the Technical Regulator.
- Minimum clearances d and e also apply to any combustion air intake openings of appliances.

5. Installation of the Water Heater

5.1 Securing the Water Heater to the wall

⚠ WARNING

Do not drop or apply unnecessary force to the appliance when installing. Internal parts may be damaged and may become highly dangerous.

⚠ CAUTION

- Protect your hands with gloves and take caution to not inflict injury.
- Be careful not to hit electrical wiring, gas, or water piping while drilling holes.

NOTICE

- Installation must conform with all local building, water or Gas Regulations or AS/NZS 5601.
- The weight of the appliance will be applied to the wall. If the strength of the wall is not sufficient, reinforcement must be made to prevent the transfer of vibration.
- Install the appliance on a vertical wall and ensure that it is level.
- Ensure no additional pressure is applied to the pipework.

1. Drill a single screw hole, making sure to hit a stud, or into a solid masonry surface.
2. Insert and tighten the screw and hang the Water Heater by the upper wall mounting bracket.

3. Determine the positions for the remaining four screws (two for the top bracket and two for the bottom), and remove the Water Heater.

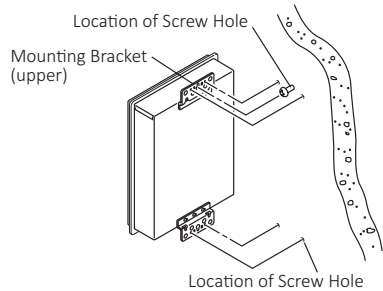

4. Drill holes for the remaining four screws.
5. Hang the Water Heater again by the first screw, and then insert and tighten the remaining four screws.
6. Take waterproofing measures so that water does not enter the building from screws mounting the device.

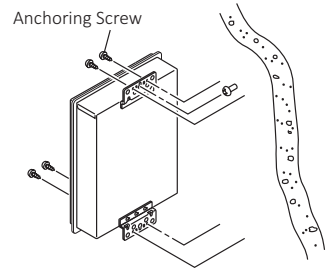

7. Make sure the Water Heater is installed securely so that it will not fall or move due to vibrations or earthquakes.

NOTE For a masonry wall follow the same process but use suitable plugs or dynabolts (not supplied).

5.2 Elevation Adjustment Above 600 m (26ENG series only)

If installation altitude is higher than 600 m, contact DUX to change the altitude settings.

6. Connecting the Gas Supply

Follow the instructions from the gas supplier.

Gas Type

The gas type indicated on the Water Heater's rating plate (NG or ULPG) must match the type of gas being supplied to the Water Heater.

Gas Meter

Select a gas meter capable of supplying the entire MJ/h demand of all gas appliances in the building.

Gas Connection

1. Fit a union to the Water Heater gas inlet for easy connection and removal. The thread diameter is 20 mm.

NOTE THIS DOES NOT INDICATE THE SIZE OF THE GAS SUPPLY.

2. Fit an suitably approved isolating gas cock in the supply pipe adjacent to the Water Heater gas connection.
3. Ensure that the supply pipe and the gas pressure regulator (ULPG or Natural Gas) has sufficient flow capacity for this and other appliances connected to the fitting pipe.
4. For ULPG appliances ensure that gas cylinders are of sufficient size. The Water Heater alone will require 2 × 45 Kg capacity cylinders.
5. Before connecting the appliance to the gas service, purge any debris or air from the gas service.
6. Check all joints for leaks with an approved leak tester after connection.

Pressure

Ensure measurement is taken when the appliance and all other gas appliances connected to the meter are running at max load.

WARNING

The inlet gas pressure must be within the range specified.
This is for the purposes of input adjustment.

Pressure Test

The appliance and its gas connections must be leak tested before placing the appliance in operation.

If test pressures are in excess of 1/2 psi (3.5 kPa), the appliance must be completely disconnected from the gas supply piping system during the test process.

Measuring Gas Pressure

- In order to check the gas supply pressure to the Water Heater, a tap is provided on the gas inlet.

1. Remove the hex head phillips screw from the tap.
2. Connect a manometer using a silicon tube.

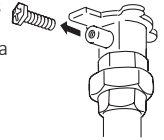

- In order to check the gas manifold pressure on the gas valve inside the Water Heater. The pressure can be checked by removing the hex head phillips screw and connecting a manometer with a silicon tube.

Pipe Sizing

- In order to choose the proper size for the gas pipe, consult local codes and/or the AS/NZS 5601.
- Size the gas pipe according to total MJ/h demand of the building and length from the meter or regulator so that the following supply pressures are available even at maximum demand refer AS/NZS 5601:

	Supply Pressure	
	Natural Gas	ULPG Gas
Min	1.13 kPa	2.75 kPa
Max	3.00 kPa	3.50 kPa

WARNING

Gas pressures below or above the required minimum or maximum pressure may result in ignition failure, personal injury or death.

- NOTE**
- Ensure that the gas pipe size is correct. If undersized the appliance will not operate correctly.
 - SERVICE CALLS ARE CHARGEABLE FOR UNITS WITH INCORRECT PIPE SIZES OR BLOCKED GAS OR WATER FILTERS.

Flexible Connectors

Flexible gas pipes are not recommended unless the minimum inside diameter is 3/4 in. or greater and the rated capacity of the connector is equal to or greater than the MJ/h demand of the Water Heater.

Reference Tools & Sample Calculations

NOTICE

The tables and samples below are for reference only. The professional sizing and installing the gas pipe should always run the appropriate calculations before all installations.

[Calculation Example]

A partial set of sizing tables are printed on page 17-18.

1. Draw a sketch of a piping system.
Enter the system information.

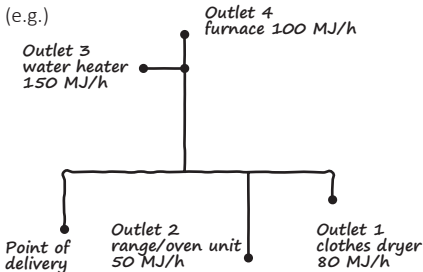

2. Determine the gas type used and supply gas Pressure, and enter it.
- Determine the piping material and enter it to the below.
- Select the appropriate pipe sizing table from page 17-18 and enter it to the below.

(e.g.)

Gas type: Natural

Supply gas pressure: 1.13

Piping material: Copper

Table used: 1

Pressure drop: 0.12 kPa

Gas type: _____

Supply gas pressure: _____

Piping material: _____

Table used: _____

Pressure drop: _____

3. On the sketch, mark the delivery point (meter or regulator) as "a" and the first tee as "b". Let the section "a-b" be the first section.
- Section from the first tee "b" to the second tee "c" set "b-c" and set the section to the next tee in the same way.

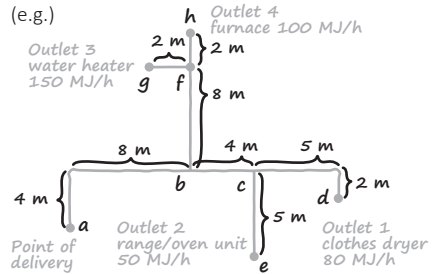

4. • Enter the demand which is the amount of gas flowing through a section of pipe in the table below.
- Enter the length for all pipe sections in the table below.
- Round up to the lengths in the appropriate table on page 17-18. Read across until a capacity equal to or greater than the required demand for the section is found. Read up to find the size. Repeat for each section of piping. Enter this size in the table below.

(e.g.)

Section	Demand	Length	Size
a b	Outlet 1+2+3+4= 380 MJ/h	12 m	40 mm
b c	Outlet 1+2= 130 MJ/h	4 m	20 mm
c d	Outlet 1= 80 MJ/h	7 m	20 mm
c e	Outlet 2= 50 MJ/h	5 m	20 mm
b f	Outlet 3+4= 250 MJ/h	8 m	25 mm
f g	Outlet 3= 150 MJ/h	2 m	20 mm
f h	Outlet 4= 100 MJ/h	2 m	20 mm

Section	Demand	Length	Size

5. • Enter the input rating for each appliance in the table below.
- Enter the length from each appliance to the nearest tee in the outlet length in the table below.
- Round up to the lengths in the appropriate table on page 17-18. Read across until a capacity equal to or greater than the required demand for the section is found. Read up to find the size. Repeat for each appliance. Enter this size in the table below.

(e.g.)

Appliance	Demand	Outlet length	Size
Outlet 1	80 MJ/h	7 m	20 mm
Outlet 2	50 MJ/h	5 m	20 mm
Outlet 3	150 MJ/h	2 m	20 mm
Outlet 4	100 MJ/h	2 m	20 mm

Appliance	Demand	Outlet length	Size
Outlet 1			
Outlet 2			
Outlet 3			
Outlet 4			

Final Check

1. Turn on and operate all gas appliances including the Water Heater.
2. Ensure that the inlet pressure of each appliance is above the minimum pressure required for the appliance.

- NOTE**
- If all appliances are not receiving the minimum inlet pressure, the gas piping system may need to be changed.
 - As the gas inlet size varies depending on the area, type of gas, piping material, etc., more details should be determined after confirmation according to AS/NZS 5601.1.

[Gas pipe sizing tables]

- These tables are for reference only. Consult gas pipe manufacturer for actual pipe capacities.
- It is an example of Copper Pipe (AS 1432 Type B) and Natural Gas.
- Values in Table are in MJ of Gas per Hour.

1. Maximum Natural Gas Delivery Capacity (For supply pressure around 1.25 kPa) - COPPER PIPE (AS 1432 TYPE B) [MJ/h]																		
Pipe Size	0.12 kPa Pressure Drop																	
	Length (including fittings) : metres																	
	2	4	6	8	10	12	14	16	18	20	25	30	35	40	45	50	55	60
15	62	43	29	26	22	19	17	15	–	–	–	–	–	–	–	–	–	
20	206	141	114	97	86	78	72	67	63	59	52	48	44	41	37	33	30	28
25	452	311	249	214	189	171	158	147	138	130	115	104	96	89	84	79	75	72
32	867	596	478	409	363	329	302	281	264	249	221	200	184	171	161	152	144	138
40	1459	1002	805	689	611	553	509	474	444	420	372	337	310	288	271	256	243	232
50	3356	2307	1852	1585	1405	1273	1171	1090	1022	966	856	776	713	664	623	588	559	533
65	6217	4273	3431	2937	2603	2358	2169	2018	1894	1789	1585	1436	1321	1229	1154	1090	1035	987
80	9884	6794	5455	4669	4138	3750	3450	3209	3011	2844	2521	2284	2101	1955	1834	1732	1645	1570
100	–	–	–	–	–	–	–	–	–	6286	5571	5048	4644	4320	4054	3829	3637	3469
125	–	–	–	–	–	–	–	–	–	11520	10210	9251	8511	7918	7429	7017	6665	6358
150	–	–	–	–	–	–	–	–	–	18531	16423	14881	13690	12736	11950	11288	10720	10227
2. Maximum Natural Gas Delivery Capacity (For supply pressure around 1.5-2.5 kPa) - COPPER PIPE (AS 1432 TYPE B) [MJ/h]																		
Pipe Size	0.25 kPa Pressure Drop																	
	Length (including fittings) : metres																	
	2	4	6	8	10	12	14	16	18	20	25	30	35	40	45	50	55	60
15	93	64	51	44	39	35	32	30	28	–	–	–	–	–	–	–	–	–
20	306	210	169	145	128	116	107	99	93	88	78	71	65	61	57	54	51	49
25	672	462	371	318	281	255	235	218	205	193	171	155	143	133	125	118	112	107
32	1289	886	712	609	540	489	450	419	393	371	329	298	274	255	239	226	215	205
40	2170	1491	1197	1025	908	823	757	704	661	624	553	501	461	429	403	380	361	345
50	4993	3431	2755	2358	2090	1894	1742	1621	1521	1437	1273	1154	1061	987	926	875	831	793
65	9247	6355	5104	4368	3871	3508	3227	3002	2817	2661	2358	2137	1966	1829	1716	1621	1539	1469
80	14703	10105	8115	6945	6155	5577	5131	4773	4479	4231	3750	3397	3125	2908	2728	2577	2448	2335
100	–	–	–	–	–	–	–	–	–	9350	8287	7509	6908	6426	6030	5696	5409	5161
125	–	–	–	–	–	–	–	–	–	17136	15187	13761	12660	11777	11050	10438	9914	9458
150	–	–	–	–	–	–	–	–	–	27564	24429	22135	20363	18944	17775	16790	15946	15213
3. Maximum Natural Gas Delivery Capacity (For supply pressure around 2.75-5 kPa) - COPPER PIPE (AS 1432 TYPE B) [MJ/h]																		
Pipe Size	0.75 kPa Pressure Drop																	
	Length (including fittings) : metres																	
	2	4	6	8	10	12	14	16	18	20	25	30	35	40	45	50	55	60
15	168	115	93	79	70	64	59	54	51	48	43	39	36	33	31	29	28	27
20	554	381	306	262	232	210	193	180	169	160	141	128	118	110	103	97	92	88
25	1218	837	672	575	510	462	425	396	371	351	311	281	259	241	226	214	203	193
32	2336	1606	1289	1104	978	886	815	758	712	672	596	540	497	462	433	409	389	371
40	3931	2702	2170	1857	1646	1491	1372	1276	1197	1131	1002	908	836	777	729	689	654	624
50	9046	6217	4993	4273	3787	3431	3157	2937	2755	2603	2307	2090	1923	1789	1678	1585	1506	1437
65	16754	11515	9247	7914	7014	6355	5847	5439	5104	4821	4273	3871	3562	3313	3109	2937	2789	2661
80	26639	18309	14703	12584	11153	10105	9297	8649	8110	7665	6794	6155	5663	5268	4943	4669	4435	4231
100	–	–	–	–	–	–	–	–	–	16941	15015	13604	12516	11644	10925	10320	9801	9350
125	–	–	–	–	–	–	–	–	–	31048	27517	24932	22938	21339	20022	18912	17962	17136
150	–	–	–	–	–	–	–	–	–	49941	44262	40104	36896	34324	32205	30421	28892	27564



4. Maximum Natural Gas Delivery Capacity (For supply pressure around 5-10 kPa) - COPPER PIPE (AS 1432 TYPE B) [MJ/h]																			
Pipe Size	1.5 kPa Pressure Drop																		
	Length (including fittings) : metres																		
	2	4	6	8	10	12	14	16	18	20	25	30	35	40	45	50	55	60	
15	244	168	135	115	102	93	85	79	74	-	-	-	-	-	-	-	-	-	-
20	807	554	445	381	338	306	281	262	246	232	206	186	171	160	150	141	134	128	
25	1772	1218	978	837	742	672	619	575	540	510	452	410	377	351	329	311	295	2813	
32	3399	2336	1876	1606	1423	1289	1186	1104	1035	978	867	785	723	672	631	596	566	540	
40	5720	3931	3157	2702	2395	2170	1996	1857	1742	1646	1459	1322	1216	1131	1061	1002	952	908	
50	13161	9046	7264	6217	5510	4993	4593	4273	4009	3787	3356	3041	2798	2603	2442	2307	2191	2090	
65	24377	16754	13454	11515	10206	9247	8507	7914	7426	7014	6217	5633	5182	4821	4523	4273	4058	3871	
80	38760	26639	21392	18309	16227	14703	13526	12584	11807	11153	9887	8956	8239	7665	7192	6794	6452	6155	
100	-	-	-	-	-	-	-	-	-	-	24649	21846	19794	18210	16941	15895	15015	14260	13604
125	-	-	-	-	-	-	-	-	-	-	45174	40037	36276	33374	31048	29131	27517	26134	24932
150	-	-	-	-	-	-	-	-	-	-	72663	64400	58351	53682	49941	46858	44262	42037	40104

7. Connecting the Water Supply

- Installation and service must be performed by a qualified plumber.
- Observe all applicable codes.

7.1 Guidelines

Installation location

- If installing the Water Heater on a roof (Above lower-level hot water supply):
If the Water Heater is installed on a roof to supply water to the levels below, make sure that the water pressure supplied to the Water Heater does not drop below 199 kPa. It may be necessary to install a pump system to ensure that the water pressure is maintained at this level.
Check the pressure before putting the Water Heater into operation.
If you do not supply proper pressure to the Water Heater, noise may increase, the life of the Water Heater will be shortened, and the Water Heater may shut down frequently.

Potable water

- Piping and components connected to the Water Heater shall be suitable for use with potable water.
- Toxic chemicals, such as those used for boiler treatment, shall not be introduced into the potable water.
- A Water Heater used to supply potable water may not be connected to any heating system or components previously used with a nonpotable water heating appliance.

Valve

When water is required in one part of the system at a higher temperature than in the rest of the system, means such as a Tempering Valve shall be installed to temper the water to reduce the scald hazard.

Connecting water supply

- Flush water through the pipe to clean out metal powder, sand and dirt before connecting it.
- Use a union coupling for connecting the pipes to reduce the force applied to the piping.

- Use approved piping materials.

- NOTE**
- Avoid using joints as much as possible to keep the piping simple.
 - Avoid piping in which an air obstruction can occur.
 - Avoid connection using liquid sealant. It can cause the filter to stick, and may be torn.

Cold water supply

NOTICE

No pressure reduction is required unless the water pressure exceeds 1,000 kPa.

- Pipe and fittings must meet the installation requirements of AS/NZS 3500.4 and local authority regulations.
- An isolating valve must be installed on the water inlet in close proximity to the Water Heater.
- A GATE VALVE OR BALL VALVE must be used on the cold water inlet to the Water Heater, THIS REQUIREMENT IS AN AUSTRALIA WIDE REQUIREMENT UNDER THE NATIONAL PLUMBING CODE. STOP TAPS OR COMBINATION STOP TAPS AND NON-RETURN VALVES ARE NOT TO BE USED.
- The Water Heater needs a minimum water supply pressure of 200 kPa to operate.
- Maximum water supply pressure must not exceed 1,000 kPa.
- If the water pressure is too high, use a Pressure Reducing Valve and a Water Hammer Arrester.
- The unit is fitted with a pressure relief valve. In some circumstances, there may be small amounts of water droplets appearing from pressure relief valve. If required pressure relief valve should be connected to a suitable drain.

Hot water supply

⚠ WARNING

For any sanitary fixture used for personal hygiene, the delivered hot water temperature shall not exceed 50°C for Australia and 55°C for New Zealand.

For Australia, models which are not 50°C compliant should be fitted with a temperature control device meeting the appropriate plumbing code requirements.

- Pipe and fittings must meet the installation requirements of AS/NZS 3500.4.
- Hot water lines should be lagged with suitable insulating material.
- DO NOT FIT ANY VALVES OR RESTRICTORS TO THE OUTLET OF THE WATER HEATER.
- DO NOT FIT ANY OBSTRUCTION TO THE PRESSURE RELIEF LOCATED ON THE HOT WATER OUTLET CONNECTION.

[(50°C Compliant Models Only) Minimum Distances]

In order to comply with AS 3498 the minimum distances as per the diagram below must be observed.

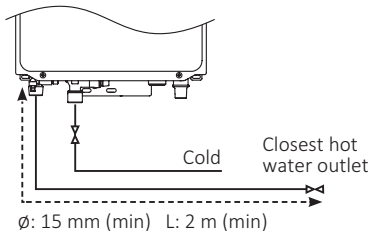

Commission Check for 50°C Temperature Delivery

A temperature check must be completed at the nearest outlet to the Water Heater to ensure delivered water is below 50°C.

To check the water temperature is below 50°C.

1. At the closest outlet adjust the hot water flow to at least 5 litres/min.
2. After hot water has been running for 1 min confirm the water temperature is below 50°C.
3. Turn the water off.

7.2 Freeze Prevention

Perform the following insulation measures for prevention of freezing.

- Take appropriate heat insulation measures (e.g. wrapping with heat insulation materials, using heat tape, electric heaters, solenoids, or pipe covers) according to the climate of the region to prevent the plumbing external to the Water Heater from freezing. The freeze prevention heaters will not prevent this plumbing from freezing.
- Make sure that there are no water leaks from the cold and hot water supply lines, then insulate the pipes completely.
- Be sure to also completely insulate the water supply valve and the cold and hot water connections on the Water Heater.

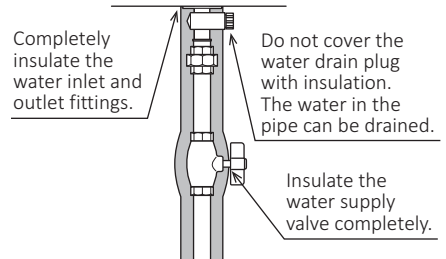

7.3 After Installing the water supply piping

After purging the air from the system using the hot water supply taps, remove the water inlet strainer located on the cold water supply inlet connection. Remove any debris from the filter and replace. When replacing the filter, do not over-tighten the Sealing.

8. Connecting Electricity

Water Heater

WARNING

Electrical Shock Hazard

Do not connect the electrical power to the appliance until all Remote Controllers have been connected.
It may result in death or serious injury from electrical shock.

CAUTION

Electrostatic discharge can affect electronic components.
Take precautions to prevent electrostatic discharges from personnel or hand tools during the Water Heater installation and servicing to protect product's electronic control.

Power Supply

- The Water Heater is equipped with a 1.5 m cable with a three pinned earthed plug to be connected to 230- 240 VAC at 50 Hz.
The power consumption may be up to 17ENG series 147 W, 21ENG series 155 W, 26ENG series 166 W.
Use an appropriate circuit.
- The Water Heater requires 230-240 VAC 50 Hz in Australia and New Zealand, weatherproof plug installed in a protected position adjacent to the appliance.
- If the power cord is damaged and requires replacement, use only an original spare part available from the manufacturer.
- Tie the redundant power cord outside the Water Heater. Putting the redundant length of cord inside the Water Heater may cause electrical interference and faulty operation.

- NOTE**
- Do not let the power cord contact the gas piping.
 - Do not disconnect the electrical power when not in use. When the power is off, the freeze prevention in the Water Heater will not operate, resulting in possible freezing damage.

Ground

To prevent electrical shock and ensure correct operation, always plug power lead into an earthed point.

9. Remote Controller

Suitable remote controller combinations:

Main Controller	Bath Room Controller		Operation
	RCB1D	RCB2D	
RCM1D			Works
✓			Works
	✓		Won't work
		✓	Won't work
✓	✓		Works
✓	✓	✓ (× 2)	Works
✓		✓ (× 2)	Won't work
	✓	✓ (× 2)	Won't work

Maximum number of installed:

Main Controller	RCM1D	1
Bath Room Controller	RCB1D	1
	RCB2D	2-3
Total		4

9.1 Connecting Remote Controller Cord to the Water Heater

- NOTE**
- Tie the excess cord outside the Water Heater. Do not put the extra length inside the Water Heater.
 - The remote controller cord can be extended up to 35 m.
 - Be sure to hand tighten when screwing to the terminal block. Power tools may cause damage to the terminal block.

- Use remote controller cord for any extensions.
 - Install according to the National Electrical Code and all applicable local codes.
1. Disconnect the electrical power to the Water Heater.
 2. Leave enough slack so that the remote controller cord will not be damaged if the Water Heater is removed from the wall.
 3. Remove the front cover (4 screws).
 4. Pass the remote controller cord through the wiring throughway and into the Water Heater.
 5. Connect the Y-shaped terminals at the end of the remote controller cord to the terminal block.
 6. Secure the remote controller cord with a clamp.
 7. Reattach the front cover.

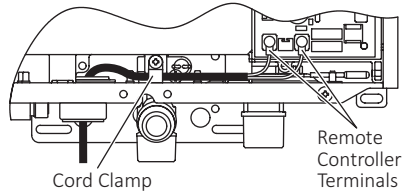

9.2 Temperature Setting

⚠ WARNING

When changing the temperature, make sure to confirm with the customer that the temperature of the hot water will be very high and that there is a risk of scalding.

To ensure compliance with Australian Standard AS/NZS 3500.4, for sanitary areas, install the Water Heater with a tempering valve. In New Zealand, please refer to the New Zealand Building Code and all other applicable electrical, gas fitting and plumbing codes. Temperature is controlled by the maximum temperature set in the Water Heater.

The procedure for changing the maximum temperature setting

NOTE This setting ("F03") must be done with all hot water fixtures closed within the first 10 minutes of connecting the electrical power to the Water Heater.

1. Turn the Water Heater off at the powerpoint.

NOTE Do not use the Water Heater while temperature setting.

2. Remove the front cover (4 screws).
3. Turn the power back on.
 - 1) Press and hold MODE button for 2 seconds, and set the DISPLAY to "F03" using UP or DOWN button.
 - 2) Press MODE button once when DISPLAY lights "F03".
 - Switch to SELECT mode.
 - 3) Select the temperature using UP or DOWN button.

NOTE (For 26ENG series)

If you want to use hot water above 60°C, press the UP button 10 times in a row with "60" displayed.

50°C model: 37-48°C (In 1°C intervals), 50°C
 55°C model: 37-48°C (In 1°C intervals), 50°C,
 55°C, 60°C, 65°C, 70°C

- 4) After selecting the temperature, press MODE button again for 2 seconds.
 - Displayed for a few seconds, then the new temperature is locked in. If "---" is not displayed turn the power off at the power point and wait 10 seconds, then turn the power back on and repeat step 3.

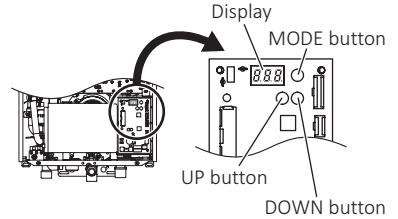

4. Reattach the front cover (4 screws).

NOTE (For 26ENG series)

- If you want to set the water heaters temperature at 70°C, please change it using the Status Display monitor, even if the Remote Controller is installed. The maximum temperature setting via the Remote Controller is 60°C.
- If you want use it less than 42°C, call DUX on 1300 365 115 (in Australia) or 0800 729 389 (in New Zealand).

(°C)

		MODE button	Maximum Temperature Setting	Without Controller	Main Controller	Bath Room Controller	
					RCM1D	RCB1D	RCB2D
50°C model	26ENG5 N/L 21ENG5 N/L 17ENG5 N/L	Factory Setting	50	50	37-48, 50	37-48, 50	
		F03	37	37	37	37	
			⋮	⋮	⋮	⋮	
			48	48	37-48	37-48	
55°C model	26ENG6 N/L	Factory Setting	55	55	37-48, 50, 55	37-48, 50	
		F03	37	37	37	37	
			⋮	⋮	⋮	⋮	
			48	48	37-48	37-48	
			50	50	37-48, 50	37-48, 50	
			55	55	37-48, 50	37-48, 50	
			60	60	37-48, 50, 55, 60	37-48, 50	
			65	65	37-48, 50, 55, 60	37-48, 50	
	70	70	37-48, 50, 55, 60	37-48, 50			
	21ENG6 N/L 17ENG6 N/L	Factory Setting	55	55	37-48, 50, 55	37-48, 50	
		F03	37	37	37	37	
			⋮	⋮	⋮	⋮	
			48	48	37-48	37-48	
			50	50	37-48, 50	37-48, 50	
			55	55	37-48, 50	37-48, 50	
			60	60	37-48, 50, 55, 60	37-48, 50	

NOTE Maximum temperature is controlled by the maximum default temperature set in the Water Heater.

10. Trial Operation

The installer should test operate the Water Heater, explain to the customer how to use the Water Heater, and give the owner this manual before leaving the installation.

Trial Operation

⚠ DANGER

There is a possibility of scald if the setting temperature is too high.

If overheating occurs, or the gas supply fails to shut off, turn off gas supply valve to the unit.

- NOTE**
- White smoke may be noticed from the exhaust vent during cold weather. This is not a malfunction of the Water Heater.
 - If the Water Heater does not operate normally, refer to “Troubleshooting” in the Owner’s Guide.

1. Open a hot water fixture to confirm that water is available, and then close the fixture.
2. Open the gas supply valve.
3. Turn on the Operation button on the Remote Controller (the Operation indicator will turn on).
4. Open a hot water fixture and confirm that the Burner on indicator of Remote Controller turns on, and that hot water is being produced.

- NOTE** If an error code “11” appears on the Remote Controller, air may be trapped in the gas pipe.
- 1) Close a hot water fixture.
 - 2) Turn the unit off and then back on.
 - 3) Open a hot water fixture again.
 - 4) If necessary, repeat until the air is completely purged from the gas pipe.

5. Check that the hot water temperature changes by pressing the ↑ / ↓ buttons.
6. After the trial operation, clean the filter in the cold water inlet according to the procedure as follows.

- 1) Close the water supply valve.

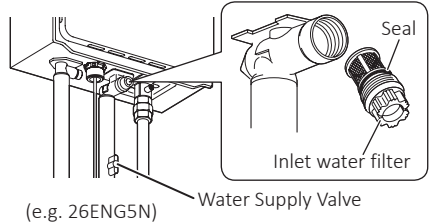

- 2) Open all hot water fixtures.
- 3) With a bucket ready, remove the inlet water filter. (about 1 L will drain out)
- 4) Clean the inlet water filter with a brush under running water.
- 5) Reattach and close inlet water filter.

NOTE Do not lose the seal.

- 6) Close all hot water fixtures.
- 7) Open the water supply valve and check that water does not leak from the inlet water filter.

If error codes “11”, “12”, and “90” appear, check the following contents.

["11" : Ignition failure, "12" : Flame loss]

- Check that the gas supply pipe is appropriately sized.
- Check that the gas supply pressure is within the ranges required in this manual.
- Check that the gas supply matches the type indicated on the Water Heater’s rating plate.
- Air may be left in the gas piping. Repeat the power ON/OFF.

["90" : Combustion abnormality]

- Check that the air supply / exhaust vent for blockage.
- Check that the gas supply pressure is within the ranges required in this manual.
- Check that the piping is not frozen or clogged.

If other error codes appear, refer to the wiring diagram which is put in the back of the front cover.



Handling after trial operation

If the Water Heater will not be used immediately, close all gas and water valves, and drain all of the water out of the Water Heater and the plumbing system to prevent the Water Heater and system from freezing, and discharge the gas out of the gas pipe.

NOTICE

Freezing is not covered by the warranty.

Lighting Instructions

⚠ WARNING

A fire or explosion may result if these instructions are not followed, which may cause death, personal injury or property damage.

This Water Heater does not have a pilot. It is equipped with an ignition device that automatically lights the burner.

Do not try to light the burner by hand.

1. Read the safety information in the installation manual or on the right side of the Water Heater.
2. Turn off all electrical power to the Water Heater.
3. Do not attempt to light the burner by hand.
4. Turn the gas control manual valve (external to the Water Heater) clockwise to the off position.
5. Wait five minutes to clear out any gas. If the smell of gas remains, stop, and follow the instructions on page 3 of Owner's Guide.
6. Turn the gas control manual valve counterclockwise to the on position.
7. Turn on the electrical power to the Water Heater.
8. The Water Heater will now operate whenever hot water is needed. If the Water Heater will not operate, follow the shutdown instructions and call a service technician.

Shutdown Instructions

1. Stop any water demand.
2. Turn off the electrical power.
3. Turn the gas control manual valve clockwise to the off position.

NOTE If the water heater is to be left switched off, follow the drain procedure in the owners manual.

11. Maintenance

11.1 Periodic Check

- Check the following to ensure proper operation of the Water Heater periodically .
- Also check the items of maintenance described in the Owner's Guide or consult the manufacturer for recommended service checks.

[Burner]

- Check the burner flame periodically for a proper blue color and consistency.
- If the flame does not appear normal, the burner may need to be cleaned by a qualified service technician.

[Water filter]

- Check and clean the filter inside of cold inlet connection.

NOTICE

Do not use this appliance if any part has been under water. Immediately call a qualified service technician to inspect the appliance and to replace any part of the control system and any gas control which has been under water.

11.2 WATER QUALITY

All Dux water heating appliances are constructed from high quality materials and components and all are certified for compliance with relevant parts of Australian and New Zealand gas, electrical and water standards.

Whilst Dux water heaters are warranted against defects, the warranty is conditional upon correct installation and use, in accordance with detailed instructions provided with the heater. In the case of the water supplied to the heater, it is important that the water quality be of acceptable standard.

The water quality limits/parameters listed in water quality table are considered acceptable and generally, Australian and New Zealand suburban water supplies fall within these limits/parameters.

In areas of Australia and New Zealand where water may be supplied, either fully or partly, from bores, artesian wells or similar, one or more of the important limits may well be exceeded and the heater could, therefore, be at risk of failure.

Where uncertainty exists concerning water quality, intending appliance users should seek a water analysis from the water supplying authority and in cases where it is established that the water supply does not meet the quality requirements of the water quality table, the Dux warranty would not apply.

WATER QUALITY TABLE

Maximum levels:

pH	6.5-8.5
Saturation Index (LSI) (langelier)	+0.4 to Minus 1.0 @65C
Total Hardness	200 mg/L
Hardness (as CaCO ₃)	200 mg/L
Chlorides	250 mg/L
Sodium	150 mg/L
Iron	1 mg/L
Silicon Dioxide (SiO ₂)	50 mg/L
TDS	600
Dissolved CO ₂	25 mg/L
Magnesium	10 mg/L

